

Kozy-World®

BLUE FLAME VENT-FREE
PROPANE GAS SPACE
HEATER

OWNER'S OPERATION AND INSTALLATION MANUAL

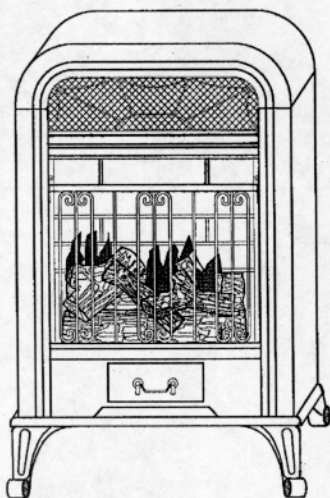

GSP1012

Table of Contents

Safety Information Warning.....	2
Air For Combustion & Ventilation.....	4
Installation.....	6
Operating Heater.....	10
Cleaning & Maintenance.....	11
Trouble Shooting.....	12
Replacement Parts.....	14
Parts Breakdown & Parts List.....	15



World Marketing of America, Inc.
P.O. Box 192, Rt. 22 West
Mill Creek, PA 17060

KOZY WORLD PHONE NUMBER: (814) 643-1775
<http://www.worldmktng.com>

⚠ WARNING: If the information in this manual is not followed exactly, a fire or explosion may result causing property damage, personal injury, or loss of life.

⚠ WARNING: This is an unvented gas-fired heater. It uses air (oxygen) from the room in which it is installed. Provisions for adequate combustion and ventilation air must be provided. Refer to Air For Combustion and Ventilation section on page 4 of this manual.

Do not store, or use gasoline or other flammable vapors and liquids in the vicinity of this or any other appliance.

WHAT TO DO IF YOU SMELL GAS

- Do not try to light any appliance.
- Do not touch any electrical switch; do not use any phone in your building.
- Immediately call your gas supplier from a neighbor's phone. Follow the gas supplier's instructions.
- If you cannot reach your gas supplier, call the fire department.

Installation and service must be performed by a qualified installer, service agency or gas supplier.

⚠ WARNING: Improper installation, adjustment, alteration, service or maintenance can cause injury or property damage. Refer to this manual for correct installation and operational procedures. For assistance or additional information consult a qualified installer, service agency, or gas supplier.

This appliance may be installed in an aftermarket* permanently located, manufactured (mobile) home, where not prohibited by local codes.

This appliance is only for use with the type of gas indicated on the rating plate. This appliance is not convertible for use with other gases.

*Aftermarket: Completion of sale, not for purpose of resale, from the manufacturer.

Save this manual for future reference.

SAFETY INFORMATION WARNINGS

IMPORTANT: Read this owner's manual carefully and completely before trying to assemble, operate, or service this heater. Improper use of this heater can cause serious injury or death from burns, fire, explosion, electrical shock, and carbon monoxide poisoning.

⚠ DANGER: Carbon monoxide poisoning may lead to death!

Carbon Monoxide Poisoning: Early signs of carbon monoxide poisoning resemble the flu, with headache, dizziness, and/or nausea. If you have these signs, heater may not be working properly. Get fresh air at once! Have heater serviced.

Some people—pregnant women, persons with heart or lung disease, anemia, those under the influence of alcohol, those at high altitudes—are more affected by carbon monoxide than others.

Propane/LP Gas: Propane/LP gas is odorless. An odor-making agent is added to Propane/LP gas. The odor helps you detect a Propane/LP gas leak. However, the odor added to Propane/LP gas can fade. Propane/LP gas may be present even though no odor exists.

Make certain you read and understand all warnings. Keep this manual for reference. It is your guide to safe and proper operation of this heater.

⚠ WARNING: Any change to this heater or its controls can be dangerous.

⚠ WARNING: Do not allow fans to blow directly into the heater. Avoid any drafts that alter burner flame patterns. Ceiling fans can create drafts that alter burner flame patterns. Altered burner patterns can cause sooting.

⚠ WARNING: Do not use accessories not approved for use with this heater.

Due to high temperatures, the appliance should be located out of traffic and away from combustible materials.

Do not place clothing or other flammable material on or near the appliance.

Children and adults should be alerted to the hazard of high surface temperature and should stay away to avoid burns or clothing ignition. Heater will remain hot for a time after shutdown. Allow surfaces to cool before touching.

Young children should be carefully supervised when they are near the appliance.

Any safety screen or guard removed for servicing the appliance must be replaced prior to operating the heater.

The appliance should be inspected before each use. Frequent cleaning may be required. The control compartments, burners and circulating air passageways of the appliance must be kept clean.

⚠ WARNING: If the recreational or commercial enclosure does not have a window or roof vent, **DO NOT USE THIS HEATER** inside.

1. This appliance is only for use with the type of gas indicated on the rating plate. This appliance is not convertible for use with other gases.
2. If you smell gas
 - Shut off gas supply.
 - Do not try to light any appliance.
 - Do not touch any electrical switch; do not use any phone in your building.
 - Immediately call your gas supplier from a neighbor's phone. Follow the gas supplier's instructions.
 - If you cannot reach your gas supplier, call the fire department.
3. This heater shall not be installed in a bathroom.

4. Do not use this heater as a wood-burning heater. Use only the logs provided with the heater.
5. Do not add extra logs or ornaments such as pine cones, vermiculite, or rock wool. Using these added items can cause sooting. Do not add lava rock around base. Rock and debris could fall into the control area of heater. After servicing, always replace screen before operating heater.
6. When used without adequate combustion and ventilation air, this heater may give off excessive CARBON MONOXIDE, an odorless, poisonous gas.
7. This heater is designed to be smokeless. If logs ever appear to smoke, turn off heater and call a qualified service person. Note: During initial operation, slight smoking could occur due to log curing and heater burning manufacturing residues.
8. To prevent the creation of soot, follow the instructions in the *Cleaning and Maintenance* Section, page 11.
9. Before using furniture polish, wax, carpet cleaner, or similar products, turn heater off. If heated, the vapors from these products may create a white powder residue within burner box or on adjacent walls or furniture.
10. This heater needs fresh air ventilation to run properly. This heater has an Oxygen Depletion Sensing (ODS) safety shutoff system. The ODS shuts down the heater if not enough fresh air is available. See the *Air for Combustion and Ventilation* Section, pages 4 through 5. If heater keeps shutting off, see *Troubleshooting*, pages 12 through 13.
11. Do not run heater
 - Where flammable liquids or vapors are used or stored.
 - Under dusty conditions.
12. Do not use this heater to cook food or burn paper or other objects.
13. Do not use this heater if any part has been under water. Immediately call a qualified service technician to inspect the heater and to replace any part of the control system, and any gas control which has been under water.

SAFETY INFORMATION

Continued

14. Turn off and unplug heater and let cool before servicing. Only a qualified service person should service and repair heater.
15. Operating heater above elevations of 4,500 feet could cause pilot outage.
16. Do not operate heater if any log is broken. Do not operate heater if a log is chipped (dime-sized or larger).

PRODUCT FEATURES SAFETY PILOT

This heater has a pilot with an Oxygen Depletion Sensing (ODS) safety shutoff system. The ODS/pilot is a required feature for vent-free room heaters. The ODS/pilot shuts off the heater if there is not enough fresh air.

PIEZO IGNITION SYSTEM

This heater has a piezo ignitor. This system requires no matches, batteries, or other sources to light heater.

LOCAL CODES

Install and use heater with care. Follow all local codes. In the absence of local codes, use the latest edition of The National Fuel Gas Code. ANSZ223.1, also known as NFPA54*.

*Available from:

American National Standards Institute, Inc.
1430 Broadway
New York, NY 10018
National Fire Protection Association, Inc.
Batterymarch Park
Quincy, MA 02269

This heater is designed for vent-free operation. State and local codes in some areas prohibit the use of vent-free heaters.

UNPACKING

1. Remove top inner pack.
2. Tilt carton so that fireplace is upright.
3. Remove protective side packaging.
4. Slide fireplace out of carton.
5. Remove protective plastic wrap.
6. Remove screen by lifting and then pulling forward.
7. Remove log set by cutting plastic ties.
8. Carefully unwrap logs.
9. Check for any shipping damage. If fireplace or logs are damaged, promptly inform dealer where you bought the fireplace from.

PRODUCT IDENTIFICATION

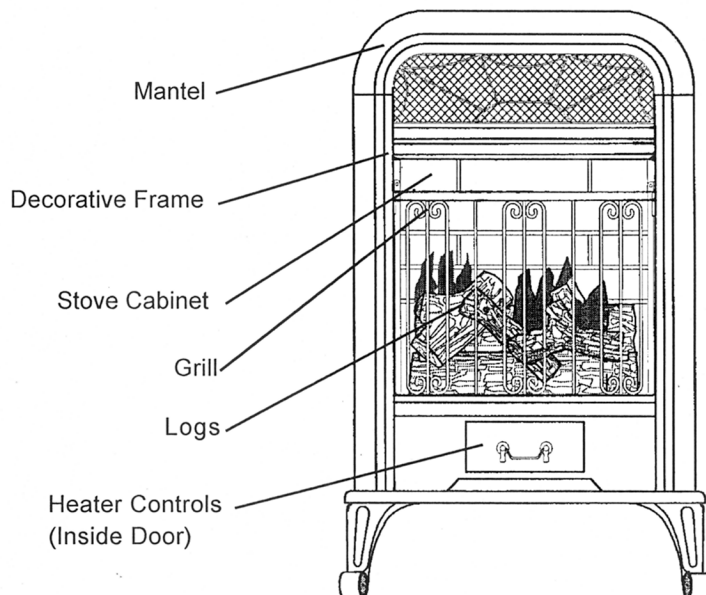

Figure1-Compact Vent-Free Stove

AIR FOR COMBUSTION AND VENTILATION

⚠ WARNING: This heater shall not be installed in a confined space or unusually tight construction unless provisions are provided for adequate combustion and ventilation air. Read the following instructions to insure proper fresh air for this and other fuel-burning appliances in your home.

PROVIDING ADEQUATE VENTILATION

The following are excerpts from National Fuel Gas Code, *NFPA 54/ANSZ 223.1. Section 5.3*, Air for Combustion and Ventilation.

All spaces in homes fall into one of the three following ventilation classifications:

1. Unusually Tight Construction
2. Unconfined Space
3. Confined Space

The information on pages 4 through 5 will help you classify your space and provide adequate ventilation.

Confined and Unconfined Space

The National Fuel Gas Code, ANS Z223.1 defines a confined space as a space whose volume is less than 50 cubic feet per 1,000 Btu per hour (4.8 m³ per kw) of the aggregate input rating of all appliances installed in that space and an unconfined space as a space whose volume is not less than 50 cubic feet per 1,000 Btu per hour (4.8 m³ per kw) of the aggregate input rating of all appliances installed in that space. Rooms communicating directly with the space in which the appliances are installed*, through openings not furnished with doors, are considered a part of the unconfined space.

This heater shall not be installed in a confined space or unusually tight construction unless provisions are provided for adequate combustion and ventilation air.

* Adjoining rooms are communicating only if there are doorless passageways or ventilation grills between them.

Unusually Tight Construction

The air that leaks around doors and windows may provide enough fresh air for combustion and ventilation. However, in buildings of unusually tight construction, you must provide additional fresh air.

Unusually tight construction is defined as construction where:

- a) walls and ceilings exposed to the outside atmosphere have a continuous water vapor retarder with a rating of one perm (6×10^{-11} kg per pa-sec-m²) or less with openings gasketed or sealed and
- b) weather stripping has been added on windows that open and doors and
- c) caulking or sealants are applied to areas such as joints around window and door frames, between sole plates and floors, between wall-ceiling joints, between wall panels, at penetrations for plumbing, electrical, and gas lines, and at other openings.

If your home meets all of the three criteria above, you must provide additional fresh air. See *Ventilation Air From Outdoors*, page 5.

If your home does not meet all of the three criteria above, proceed to *Determining Fresh-Air Flow For Heater Location*, below.

AIR FOR COMBUSTION AND VENTILATION

DETERMINING FRESH AIR FLOW FOR HEATER LOCATION

Determining if You Have a Confined or Unconfined Space

Use this worksheet to determine if you have a confined or unconfined space.

Space: Includes the room in which you will install heater plus any adjoining rooms with doorless passageways or ventilation grills between the rooms.

1. Determine the volume of the space (length \times width \times height).

Length \times Width \times Height = _____ cu.ft. (volume of space)

Example: Space size 20ft. (length) \times 16ft. (width) \times 8ft. (ceiling height) = 2560 cu. ft. (volume of space)

If additional ventilation to adjoining room is supplied with grills or openings, add the volume of these rooms to the total volume of the space.

2. Divide the space volume by 50 cubic feet to determine the maximum Btu/Hr the space can support.

_____ (volume of space) \div 50 cu. ft. = (Maximum Btu/Hr the space can support)

Example: 2560 cu. ft. (volume of space) \div 50 cu.ft. = 51.2 or 51,200 (maximum Btu/Hr the space can support)

3. Add the Btu/Hr of all fuel burning appliances in the space.

Vent-free heater	_____	Btu/Hr
Gas water heater*	_____	Btu/Hr
Gas furnace	_____	Btu/Hr
Vented gas heater	_____	Btu/Hr
Gas heater logs	_____	Btu/Hr
Other gas appliances* +	_____	Btu/Hr
Total	= _____	Btu/Hr

Example:

Gas water heater	30,000	Btu/Hr
Vent-free heater	+ 26,000	Btu/Hr
Total	= 56,000	Btu/Hr

*Do not include direct-vent gas appliances. Direct-vent draws combustion air from the outdoors and vents to the outdoors.

4. Compare the maximum Btu/Hr the space can support with the actual amount of Btu/Hr used.

_____ Btu/Hr (maximum the space can support)

_____ Btu/Hr (actual amount of Btu/Hr used)

Example : 51,200 Btu/Hr(maximum the space can support)

56,000 Btu/Hr(actual amount of Btu/Hr used)

The space in the above example is a confined space because the actual Btu/Hr used is more than the maximum Btu/Hr the space can support.

You must provide additional fresh air. Your options are as follows:

A. Rework worksheet, adding the space of an adjoining room. If the extra space provides an unconfined space, remove door to adjoining room or add ventilation grills between rooms. See *Ventilation Air From Inside Building* (below).

B. Vent room directly to the outdoors. See *Ventilation Air From Outdoors* (below).

C. Install a lower Btu/Hr heater, if lower Btu/Hr size makes room unconfined.

If the actual Btu/Hr used is less than the maximum Btu/Hr the space can support, the space is an unconfined space. You will need no additional fresh air ventilation.

⚠ WARNING: If the area in which the heater may be operated is smaller than that defined as an unconfined space or if the building is of unusually tight construction, provide adequate combustion and ventilation air by one of the methods described in the National Fuel Gas Code, ANS Z223.1, Section 5.3 or applicable local codes.

Ventilation Air From Inside Building

This fresh air would come from an adjoining unconfined space. When ventilating to an adjoining unconfined space, you must provide two permanent openings: one within 12" of the ceiling and one within 12" of the floor on the wall connecting the two spaces (see options 1 and 2, Figure 2). You can also remove door into adjoining room (see option 3, Figure 2). Follow the National Fuel Gas Code, NFPA 24/ANS Z223.1, Section 5.3, Air for Combustion and Ventilation for required size of ventilation grills or ducts.

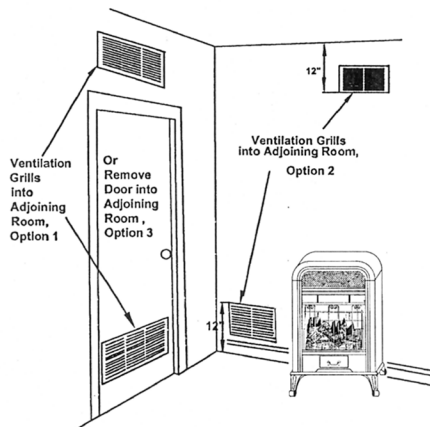

Figure 2-Ventilation Air from Inside Building

Ventilation Air From Outdoors

Provide extra fresh air by using ventilation grills or ducts. You must provide two permanent openings: one within 12" of the ceiling and one within 12" of the floor. Connect these items directly to the outdoors or spaces open to the outdoors. These spaces include attics and crawl spaces. Follow the National Fuel Gas Code, NFPA 54/ANS Z223.1, Section 5.3, Air for Combustion and Ventilation for required size of ventilation grills or ducts.

IMPORTANT: Do not provide openings for inlet or outlet air into attic if attic has a thermostat-controlled power vent. Heated air entering the attic will activate the power vent.

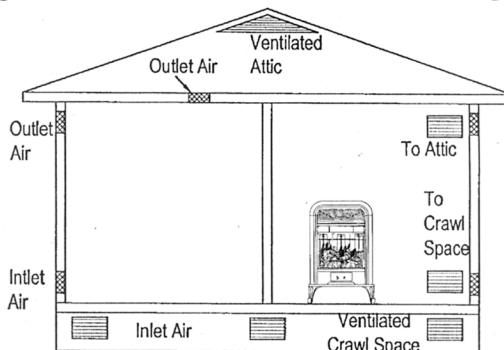

Figure 3-Ventilation Air from Outdoors

⚠ WARNING: Rework worksheet, adding the space of the adjoining unconfined space. The combined spaces must have enough fresh air to supply all appliances in both spaces.

INSTALLATION

⚠ NOTICE: This heater is intended for use as supplemental heat. Use this heater along with your primary heating system. Do not install this heater as your primary heat source. If you have a central heating system, you may run system's circulating blower while using heater. This will help circulate the heat throughout the house. In the event of a power outage, you can use this heater as your primary heat source.

⚠ WARNING: A qualified service person must install heater. Follow all local codes.

⚠ WARNING: Never install the heater:

- in a bathroom
- in a recreational vehicle
- where curtains, furniture, clothing, or other flammable objects are less than 36 inches from the front, top, or sides of the heater
- in high traffic areas
- in windy or drafty areas

⚠ CAUTION: This heater creates warm air currents. These currents move heat to wall surfaces next to heater. Installing heater next to vinyl or cloth wall coverings or operating heater where impurities (such as tobacco smoke, aromatic candles, cleaning fluids, oil or kerosene lamps, etc.) in the air exist, may discolor walls.

⚠ WARNING: Maintain the minimum clearances. If you can, provide greater clearances from floor, ceiling, and adjoining side and back walls.

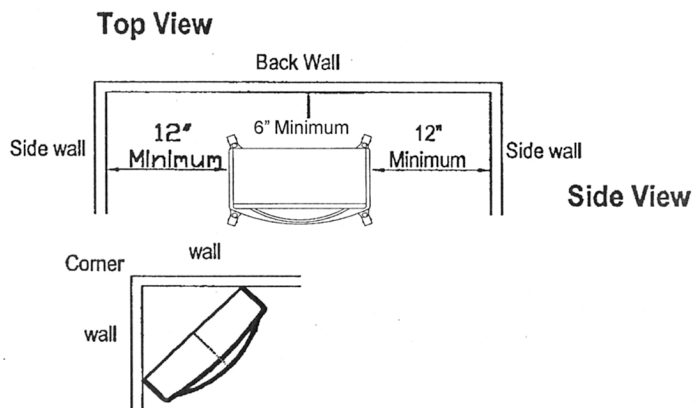
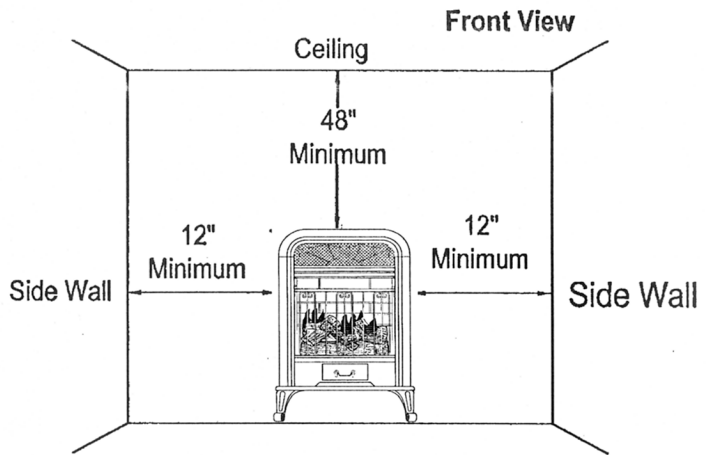

Figure 4 - Minimum Clearance to Wall

IMPORTANT: Vent-free heaters add moisture to the air. Although this is beneficial, installing heater in rooms without enough ventilation air may cause mildew. See *Air for Combustion and Ventilation*, pages 4 through 5.

CHECK GAS TYPE

Use only the type of gas indicated on the plate. If your gas supply can not meet that requirement, do not install heater. Call dealer where you bought heater for proper heater type.

CLEARANCES TO COMBUSTIBLES (Vent-Free Operation Only)

Carefully follow the instructions below. This fireplace is a freestanding unit designed to set directly on the floor.

IMPORTANT: You must maintain minimum wall and ceiling clearances during installation. The minimum clearances are shown in Figure 4. Measure from outermost point of fireplace top.

Minimum Wall and Ceiling Clearances

(see Figure 4)

- A. Clearances from outermost point of fireplace top to any combustible side wall should not be less than 12 inches.
- B. Clearances from the fireplace top to the ceiling should not be less than 48 inches.

INSTALLATION

Continued

CONNECTING TO GAS SUPPLY

WARNING: A qualified service person must connect heater to gas supply. Follow all local codes.

WARNING: Never connect heater to private (non-utility) gas wells. This gas is commonly known as wellhead gas.

CAUTION: Avoid damage to regulator. Hold gas regulator with wrench when connecting into gas piping and/or fittings.

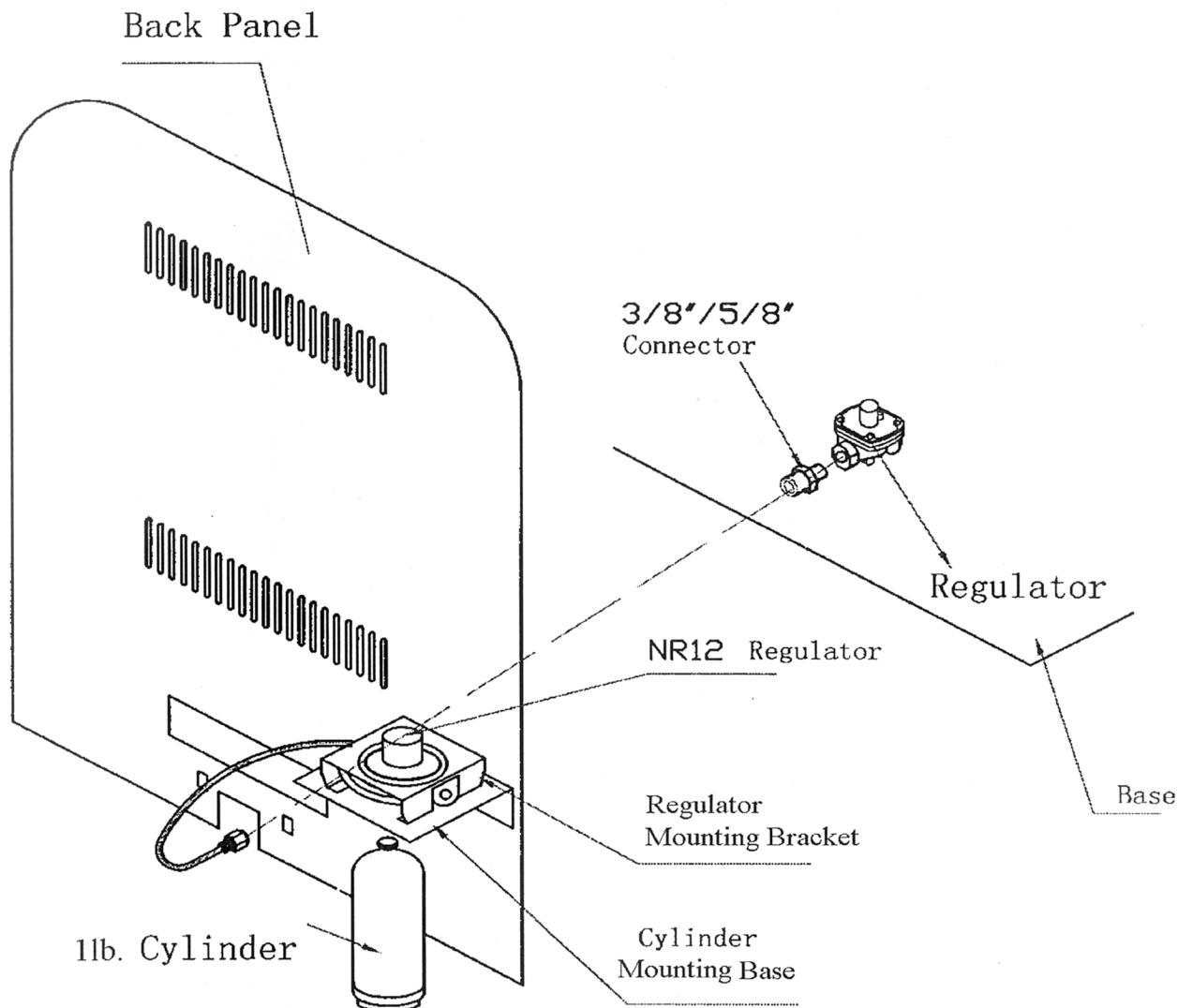

Figure 5-Install the 1 lb. cylinder

After you purchase the 1lb. cylinder, then you can begin to attach the mounting bracket onto the back panel, with four stainless steel screws. Then attach the cylinder onto the NR12 regulator. Check all connects to make sure there are no gas leaks, be sure to use soap and water and apply to all connects.

To make it convenient for you to use the cylinder, the appliance is provided with a connection both ends are 5/8", to connect the hose with the tube connection of the 1lb cylinder regulator you've bought.

NOTE: The LP-gas supply cylinder to be used must be constructed and marked in accordance with the specifications for LP-gas cylinders of the U.S. Department of Transportation (DOT).

NOTE: The LP-gas supply cylinder to be used must be provided with a cylinder connection device compatible with the connection for the heater.

INSTALLATION

Continued

CAUTION: Never connect heater directly to the gas supply. This heater requires an external regulator (not supplied). Install the external regulator between the heater and gas supply.

INSTALLATION ITEMS NEEDED

Before installing heater, make sure you have the items listed below.

- piping (check local codes)
- sealant (resistant to natural or propane/LP gas)
- equipment shutoff valve*
- test gauge connection*
- sediment trap
- see joint
- pipe wrench

* A CSA design-certified equipment shutoff valve with 1/8" NPT tap is an acceptable alternative to test gauge connection. Purchase the optional CSA design-certified equipment shutoff valve from your dealer. See *Accessories*, page 16.

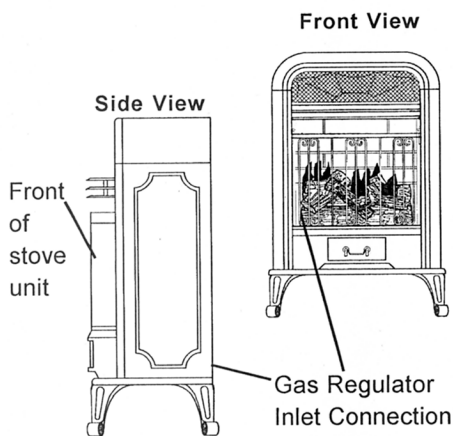

Figure 6-Gas Regulator Location and Gas Line Access Into Stove Cabinet

CHECKING GAS CONNECTIONS

1. Open gas supply valve.
2. Make sure control knob of heater is in the OFF position.
3. Apply mixture of liquid soap and water to gas joints. Bubbles forming show a leak.
4. Correct all leaks immediately.
5. Light heater (see Operating Heater, page 10). Check all other internal joints for leaks.
6. Turn off heater (see To Turn Off Gas to Appliance, page 10).

The installer must supply an external regulator. The external regulator will reduce incoming gas pressure. You must reduce incoming gas pressure to between 11 to 14 inches. If you do not reduce incoming gas pressure, heater regulator damage could occur. Install external regulator with the vent pointing down as shown in Figure 7. Pointing the vent down protects it from freezing rain or sleet.

CAUTION: Only use a new black iron or steel pipe. Internally-tinned copper tubing may be used in certain areas. Check your local codes. Use pipe of 1/2" diameter or greater to allow proper gas volume to heater. If pipe is too small, undue loss of pressure will occur.

Installation must include an equipment shutoff valve, union, and plugged 1/8" NPT tap. Locate NPT tap within reach for test gauge hook up. NPT tap must be upstream from heater (see Figure 8).

IMPORTANT: Install equipment shutoff valve in an accessible location. The equipment shutoff valve is for turning on or shutting off the gas to the appliance. Apply pipe joint sealant lightly to male threads. This will prevent excess sealant from going into pipe. Excess sealant in pipe could result in clogged heater valves.

CAUTION: Use pipe joint sealant that is resistant to liquid petroleum (LP) gas.

We recommend that you install a sediment trap in supply line as shown in Figure 8. Locate sediment trap where it is within reach for cleaning. Install in piping system between fuel supply and heater. Locate sediment trap where trapped matter is not likely to freeze. A sediment trap traps moisture and contaminants. This keeps them from going into heater controls. If sediment trap is not installed or is installed incorrectly, heater may not run properly.

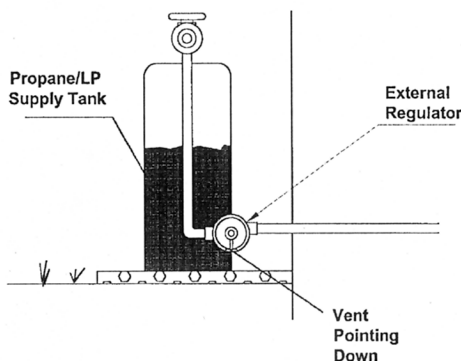

Figure 7- External Regulator With Vent Pointing Down

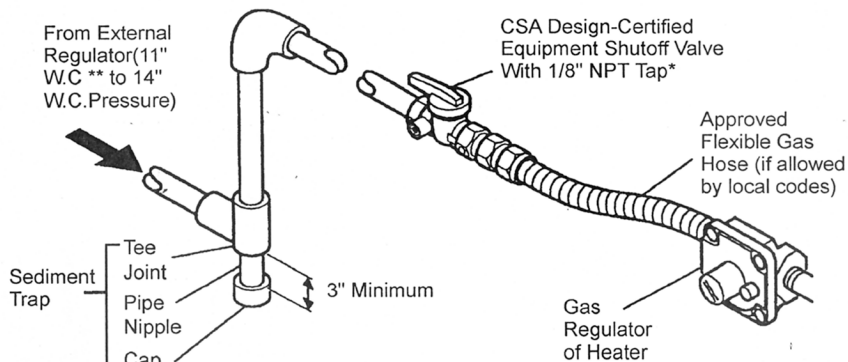

Figure 8-Gas Connection

* Purchase the optional CSA design-certified equipment shutoff valve from your dealer. See *Accessories*, page 16.

** 11" W.C. pressure is the minimum inlet pressure for purpose of input adjustment.

INSTALLATION

Continued

CHECKING GAS CONNECTIONS

⚠ WARNING: Test all gas piping and connections for leaks after installing or servicing. Correct all leaks at once.

⚠ WARNING: Never use an open flame to check for a leak. Apply a mixture of liquid soap and water to all joints. Bubbles forming show a leak. Correct all leaks immediately.

⚠ CAUTION: Make sure external regulator has been installed between natural gas supply and heater. See guidelines under Connecting to Gas Supply, page 7.

Pressure Testing Gas Supply Piping System

Test Pressures In Excess Of 1/2 PSIG(3.5kPa)

1. Disconnect heater with its appliance main gas valve (control valve) and equipment shutoff valve from gas supply piping system. Pressures in excess of 1/2 psig will damage heater regulator.
2. Cap off open end of gas pipe where equipment shutoff valve was connected.
3. Pressurize supply piping system by either using compressed air or opening propane/LP supply valve.
4. Check all joints of gas supply piping system. Apply mixture of liquid soap and water to gas joints. Bubbles forming show a leak.
5. Correct all leaks immediately.
6. Reconnect heater and equipment shutoff valve to gas supply. Check reconnected fittings for leaks.

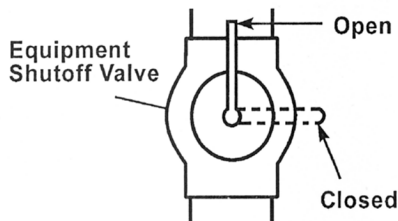

Figure 9 - Equipment Shutoff Valve

Pressure Testing Heater Gas Connections

1. Open equipment shutoff valve (see Figure 9).
2. Open gas supply valve.
3. Make sure control knob of heater is in the OFF position.
4. Check all joints from equipment shutoff valve to control valve (see Figure 10). Apply mixture of liquid soap and water to gas joints. Bubbles forming show a leak.
5. Correct all leaks immediately.
6. Light heater (see Operating Heater, page 10). Check all other internal joints for leaks.
7. Turn off heater (see To Turn Off Gas to Appliance, page 10).

Test Pressures Equal To or Less Than 1/2 PSIG (3.5 kPa)

1. Close equipment shutoff valve (see Figure 9).
2. Pressurize supply piping system by either using compressed air or opening gas supply tank valve.
3. Check all joints from gas meter to equipment shutoff valve (see Figure 10). Apply mixture of liquid soap and water to gas joints. Bubbles forming show a leak.
4. Correct all leaks immediately.

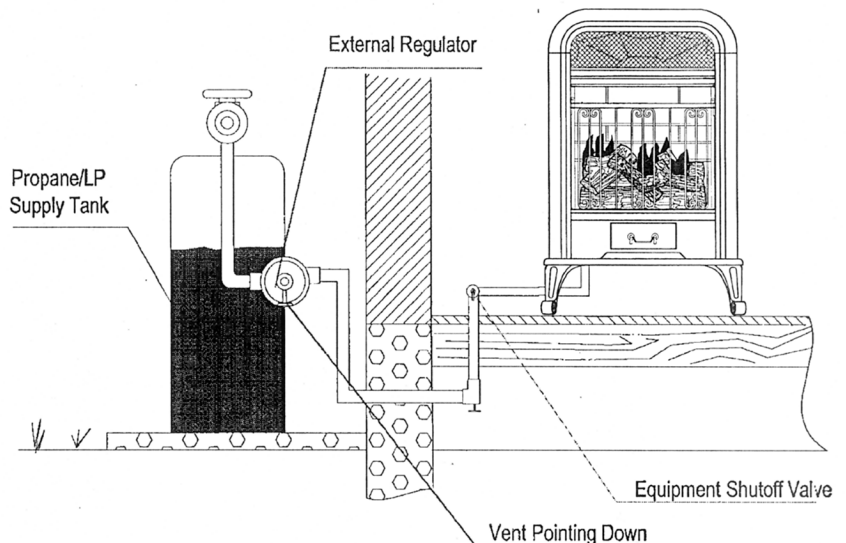

Figure 10 - Checking Gas Joints

INSTALLATION

Continued

INSTALLING LOGS

WARNING: Failure to position the parts in accordance with these diagrams may result in property damage or personal injury.

CAUTION: After installation and periodically thereafter, check to ensure that no flame comes in contact with any log. With the heater set to HIGH, check to see if flames contact any log. If so, reposition logs according to the log installation instructions in this manual. Flames contacting logs will create soot.

IMPORTANT: Make sure log does not cover any burner ports (see Figure 11).

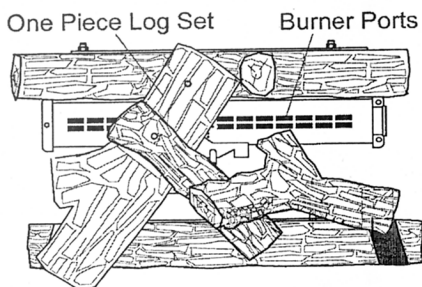

Figure 11 - Installing One-Piece Log Set (Top View)

OPERATING HEATER

■ FOR YOUR SAFETY ■
READ BEFORE
LIGHTING

WARNING: If you do not follow these instructions exactly, a fire or explosion may result causing property damage, personal injury or loss of life.

- This appliance has a pilot which must be lit by hand. When lighting the pilot, follow these instructions exactly.
- BEFORE LIGHTING** smell all around the appliance area for gas. Be sure to smell next to the floor because some gases are heavier than air and will settle on the floor.

WHAT TO DO IF YOU SMELL GAS
See WARNING on Page 2 for proper instructions.

- Use only your hand to push in or turn the gas control knob. Never use tools. If the knob will not push in or turn by hand, don't try to repair it. Call a qualified service technician or gas supplier. Force or attempted repair may result in a fire or explosion.
- Do not use this appliance if any part has been under water. Immediately call a qualified service technician to inspect the appliance and to replace any part of the control system and any gas control which has been under water.

LIGHTING INSTRUCTIONS

- STOP!** Read the safety information on page 2.
 - Make sure equipment shutoff valve is fully open.
 - Turn control knob clockwise ↻ to the OFF position.
 - Wait five (5) minutes to clear out any gas. Then smell for gas, including near the floor. If you smell gas, **STOP!** Follow "B" in the safety information on page 2. If you don't smell gas, go to the next step.
 - Turn control knob counterclockwise ↻ to the PILOT position. Press in control knob for five seconds (see Figure 12).
- Note:** You may be running this heater for the first time after hooking it up to gas supply. If so, the control knob may need to be pressed in for 30 seconds or less. This will allow air to bleed from the gas system.
- With control knob pressed in, press and release ignitor button. This will light pilot. The pilot is attached to the front burner. If needed, keep pressing ignitor button until pilot lights.

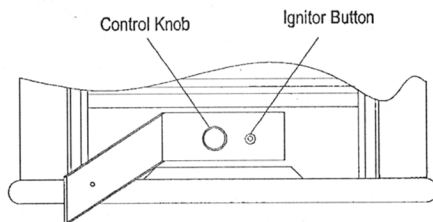

Figure 12 - Control Knob and Ignitor Button location

- Note:** If pilot does not stay lit, contact a qualified service person or gas supplier for repairs. Until repairs are made, light pilot with a match. To light pilot with a match, see *Manual Lighting Procedures*, page 11.
- Keep control knob pressed in for 30 seconds after lighting pilot. After 30 seconds, release control knob.
- If control knob does not pop out when released, contact a qualified service person or gas supplier for repairs.
- Note:** If pilot goes out, repeat steps 3 through 7. This heater has a safety interlock system. Wait one (1) minute for system to reset before lighting pilot again.
- Turn control knob counterclockwise ↻ to desired heating level. The burners should light. Set control knob to any heat level between HI and LO.

NOTICE: During initial operation of new heater, burning logs will give off a paper-burning smell. An orange flame will also be present. Open a window to vent the smell. This will only last a few hours.

TO TURN OFF GAS TO APPLIANCE

Shutting Off Heater

Turn control knob clockwise ↻ to the OFF position.

Shutting Off Burners Only (Pilot stays lit)

Turn control knob clockwise ↻ to the PILOT/IGN position.

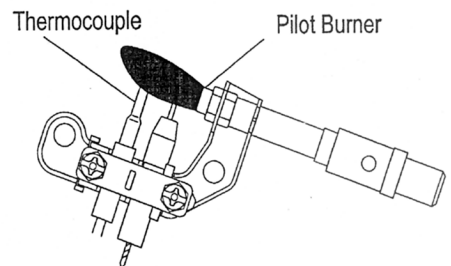

Figure 13 - Pilot

OPERATING HEATER

Continued

THERMOSTAT CONTROL OPERATION

The thermostat control knob can be set to any comfort level between HI and LO. The thermostat will gradually modulate the heat output and flame height from higher to lower settings, or pilot, in order to maintain the comfort level you select. The ideal comfort setting will vary by household depending upon the amount of space to be heated, the output of the central heating system, etc.

Note: Selecting the HI setting with the control knob will cause the burners to remain fully on, without modulating down in most cases.

MANUAL LIGHTING PROCEDURE

1. Follow steps 1 through 5 under *Lighting Instructions*, page 10.
2. Press control knob and light pilot with match.
3. Keep control knob pressed in for 30 seconds after lighting pilot. After 30 seconds, release control knob.

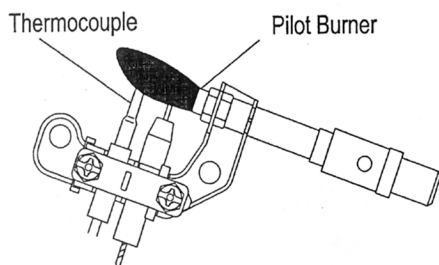

Figure 14 - Correct Pilot Flame Pattern

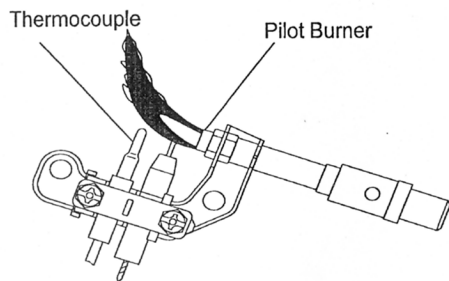

Figure 15 - Incorrect Pilot Flame Pattern

INSPECTING BURNERS

Check pilot flame pattern and burner flame patterns often.

PILOT FLAME PATTERN

Figure 14 shows a correct pilot flame pattern. Figure 15 shows an incorrect pilot flame pattern. The incorrect pilot flame is not touching the thermocouple. This will cause the thermocouple to cool. When the thermocouple cools, the heater will shut down.

If pilot flame pattern is incorrect, as shown in Figure 15:

- turn heater off (see *To Turn Off Gas to Appliance*, page 10)
- see *Troubleshooting* (pages 12 through 13).

BURNER FLAME PATTERN

Figure 16 shows a correct burner flame pattern. Figure 17 shows an incorrect burner flame pattern. If burner flame pattern is incorrect:

- turn heater off (see *To Turn Off Gas to Appliance*, page 10)
- see *Troubleshooting*, pages 12 through 13

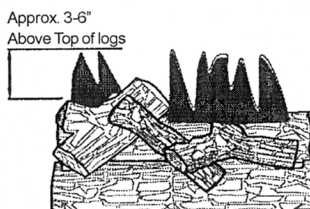

Figure 16 - Correct Flame Pattern With Control Knob Set to High Flame

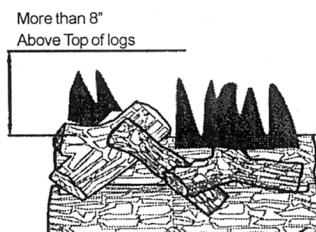

Figure 17 - Incorrect Flame Pattern With Control Knob Set to High Flame

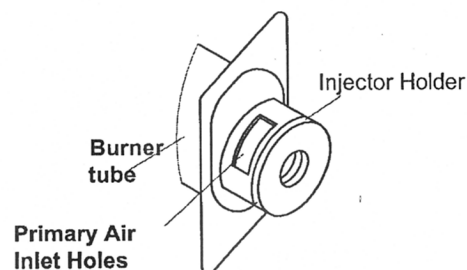

Figure 18 - Injector Holder On Outlet Burner Tube

CLEANING AND MAINTENANCE

WARNING: Turn off heater and let cool before cleaning.

CAUTION: You must keep control areas, burner, and circulating air passageways of heater clean. Inspect these areas of heater before each use. Have heater inspected yearly by a qualified service person. Heater may need more frequent cleaning due to excessive lint from carpeting, bedding material, pet hair, etc.

CLEANING ODS/IGNITOR AND BURNER

Clean with a vacuum cleaner.

CLEANING MAIN AIR INLET HOLE

We recommend that you clean the unit every three months or after 2500 hours of operation. We also recommend that you keep the burner tube and pilot assembly clean and free of dust and dirt. To clean these parts we recommend using compressed air no greater than 30 PSI. You can use a vacuum cleaner in the blow position. If using compressed air in a can, please follow the directions on the can. If you don't follow directions on the can, you could damage the pilot assembly.

1. Shut off the unit, including the pilot. Allow the unit to cool for at least thirty minutes.
2. Inspect burner, pilot and primary air inlet holes on injector holder for dust and dirt (see figure 18).
3. Blow air through the ports/slots and holes in the burner.
4. Check the injector holder located at the end of the burner tube again. Remove any large particles of dust, dirt, lint, or pet hair with a soft cloth or vacuum cleaner nozzle.
5. Blow air into the primary air holes on the injector holder.
6. In case any large clumps of dust have been pushed into the burner, repeat steps 3 and 4.

CLEANING AND MAINTENANCE

Continued

Clean the pilot assembly also. A yellow tip on the pilot flame indicates dust and dirt in the pilot assembly. There is a small pilot air inlet hole about two inches from where the pilot flame comes out of the pilot assembly (see Figure 19). With the unit off, lightly blow air through the air inlet hole. You may blow through a drinking straw if compressed air is not available.

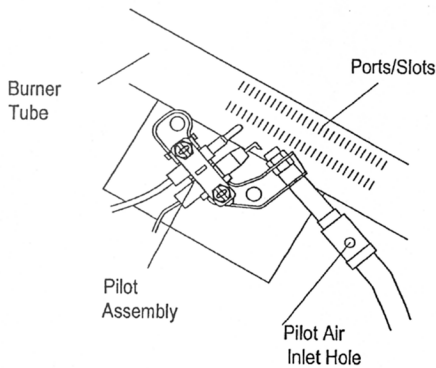

Figure 19-Pilot Air Inlet Hole

CABINET

Air Passageways

- Use a vacuum cleaner or pressurized air to clean.

EXTERIOR

- Use a soft cloth dampened with a mild soap and water mixture. Wipe the cabinet to remove dust.

LOGS

- If you remove logs for cleaning, refer to *Installing Logs*, page 20, to properly replace logs.
- Replace log(s) if broken or chipped (dime-sized or larger).

MAIN BURNER

Periodically inspect all burner flame holes with the heater running. All slotted burner flame holes should be open with yellow flame present. All round burner flame holes should be open with a small blue flame present. Some burner flame holes may become blocked by debris or rust, with no flame present. If so, turn off heater and let cool. Either remove blockage or replace burner. Blocked burner flame holes will create soot.

MAINTENANCE

1. Keeping appliance area clear and free from combustible materials, gasoline and other flammable vapors and liquids.
2. Not obstructing the flow of combustion and ventilation air.
3. Periodic visual check of pilot and burner flame, with pictorial sketches or drawings.
4. Information to adequately cover cleaning of the appliance including the burner(s) and any other special surfaces, with recommended cleaning agents, if necessary.
5. Checking and cleaning burner/venturi tubes for insects and insect nests. A clogged tube can lead to a fire.

TROUBLESHOOTING

Note: All troubleshooting items are listed in order of operation.

⚠ WARNING: Turn off heater and let cool before servicing. Only a qualified service person should service and repair heater.

⚠ CAUTION: Never use a wire, needle, or similar object to clean ODS/pilot. This can damage ODS/pilot unit.

OBSERVED PROBLEM

POSSIBLE CAUSE

REMEDY

When ignitor button is pressed, there is a spark at ODS/pilot but no ignition.

1. Gas supply turned off or equipment shutoff valve closed.
2. Control knob not in PILOT position.
3. Control knob not pressed in while in PILOT position.
4. Air in gas lines when installed.
5. Depleted gas supply.
6. ODS/pilot is clogged.
7. Gas regulator setting is incorrect.

1. Turn on gas supply or open equipment shutoff valve.
2. Turn control knob to PILOT position.
3. Press in control knob while in PILOT position.
4. Continue holding down control knob. Repeat igniting operation until air is removed.
5. Contact local propane/LP gas company.
6. Clean ODS/pilot (see Cleaning and Maintenance, page 11) or replace ODS/pilot assembly.
7. Replace gas control.

TROUBLESHOOTING

Continued

OBSERVED PROBLEM	POSSIBLE CAUSE	REMEDY
ODS/pilot lights but flame goes out when control knob is released.	<ol style="list-style-type: none"> 1. Control knob not fully pressed in. 2. Control knob not pressed in long enough. 3. Equipment shutoff valve not fully open. 4. Thermocouple connection loose at control valve. 5. Pilot flame not touching thermocouple. This allows thermocouple to cool causing the pilot flame to go out. This problem could be caused by one or both of the following: <ol style="list-style-type: none"> A) Low gas pressure. B) Dirty or partially clogged ODS/pilot. 6. Thermocouple damaged. 7. Control valve damaged. 	<ol style="list-style-type: none"> 1. Press in control knob all the way. 2. After ODS/pilot lights, keep control knob pressed in for 30 seconds. 3. Open equipment shutoff valve all the way. 4. Hand tighten until snug, then tighten 1/4 turn more. 5. A) Contact local propane/LP gas company. B) Clean ODS/pilot (see <i>Cleaning and Maintenance</i>, page 11) or replace ODS/pilot assembly. 6. Replace thermocouple. 7. Replace control valve.
Burner does not light after ODS/pilot is lit.	<ol style="list-style-type: none"> 1. Burner orifice is clogged. 2. Inlet gas pressure is too low. 3. Burner orifice diameter is too small. 4. Thermocouple leads disconnected or improperly connected. 5. Burners will not turn in remote position. 	<ol style="list-style-type: none"> 1. Clean burner (see <i>Cleaning and Maintenance</i>, page 11) or replace burner orifice. 2. Contact local propane/LP gas company. 3. Replace burner orifice. 4. Reconnect leads (see wiring diagram, page 9). 5. Replace battery in transmitter and receiver.
Delayed ignition burner.	<ol style="list-style-type: none"> 1. Manifold pressure is too low. 2. Burner orifice is clogged. 	<ol style="list-style-type: none"> 1. Contact local gas company. 2. Clean burner (see <i>Cleaning and Maintenance</i>, page 11).
Burner backfiring during combustion.	<ol style="list-style-type: none"> 1. Damaged burner. 2. Gas regulator is defective. 	<ol style="list-style-type: none"> 1. Clean burner orifice (see <i>Cleaning and Maintenance</i>, page 11). 2. Replace gas regulator.
Slight smoke or odor during initial operation.	<ol style="list-style-type: none"> 1. Residues from manufacturing processes. 2. Not enough air. 3. Gas regulator is defective. 	<ol style="list-style-type: none"> 1. Problem will stop after a few hours of operation. 2. Check burner for dirt and debris. If found, clean burner (see <i>Cleaning and Maintenance</i>, page 11). 3. Replace gas regulator.
Dark residue on logs or inside of fireplace.	<ol style="list-style-type: none"> 1. Improper log placement. 2. Air holes at burner inlet are blocked. 3. Burner flame holes are blocked. 	<ol style="list-style-type: none"> 1. Properly locate logs (see <i>Installing Logs</i>, page 10). 2. Clean out air holes at burner inlet. Periodically repeat as needed. 3. Remove blockage or replace burner.
Heater produces a clicking/ticking noise just after burner is lit or shut off.	<ol style="list-style-type: none"> 1. Metal expanding while heating or contracting while cooling. 	<ol style="list-style-type: none"> 1. This is common with most heaters. If noise is excessive, contact qualified service person.

REPLACEMENT PARTS

REPLACEMENT PARTS

Note: Use only original replacement parts. This will protect your warranty coverage for parts replaced under warranty.

PARTS UNDER WARRANTY

Contact authorized dealers of this product. If they can't supply original replacement part(s) call Kozy-World's Technical Service Department at (814)634-1775 for referral information.

When calling Kozy-World or your dealer, have ready:

- Your name
- Your address
- Model and serial numbers of your heater
- How heater was malfunctioning
- Type of gas used (propane/LP or natural gas)
- Purchase date
- Usually, we will ask you to return the defective part to the factory.

PARTS NOT UNDER WARRANTY

Contact authorized dealers of this product. Call Kozy-World's Parts Department at (814)634-1775 for referral information.

When calling Kozy-World, have ready:

- Model number of your heater
- The replacement part number

ACCESSORIES

Purchase these heater accessories from your local dealer or call Kozy-World's Sales Department at (814)634-1775 for referral information. You can also write to the address listed on the back page of this manual.

CLEANING KIT-CCK

Your vent-free gas appliance requires regulator cleaning and maintenance to prevent performance problems. This kit gives you the tools and instructions to make it easy to clean all critical areas of your heater.

SPECIFICATIONS

GSP1012

Btu	10000
Gas Type	LP Gas
Ignition	Piezo
Manifold Pressure	8"W.C.
Inlet Gas Pressure (In. of water)*	
Maximum	14"
Minimum	11"
Dimensions, Inches (HxWxD)	
Stove	33 3/8"x23 7/8"x13 29/32"
Carton	36 3/8"x26"x16 3/4"
Weight, lbs	
Stove	65
Shipping	74

**ILLUSTRATED
PARTS BREAKDOWN
GSP1012**

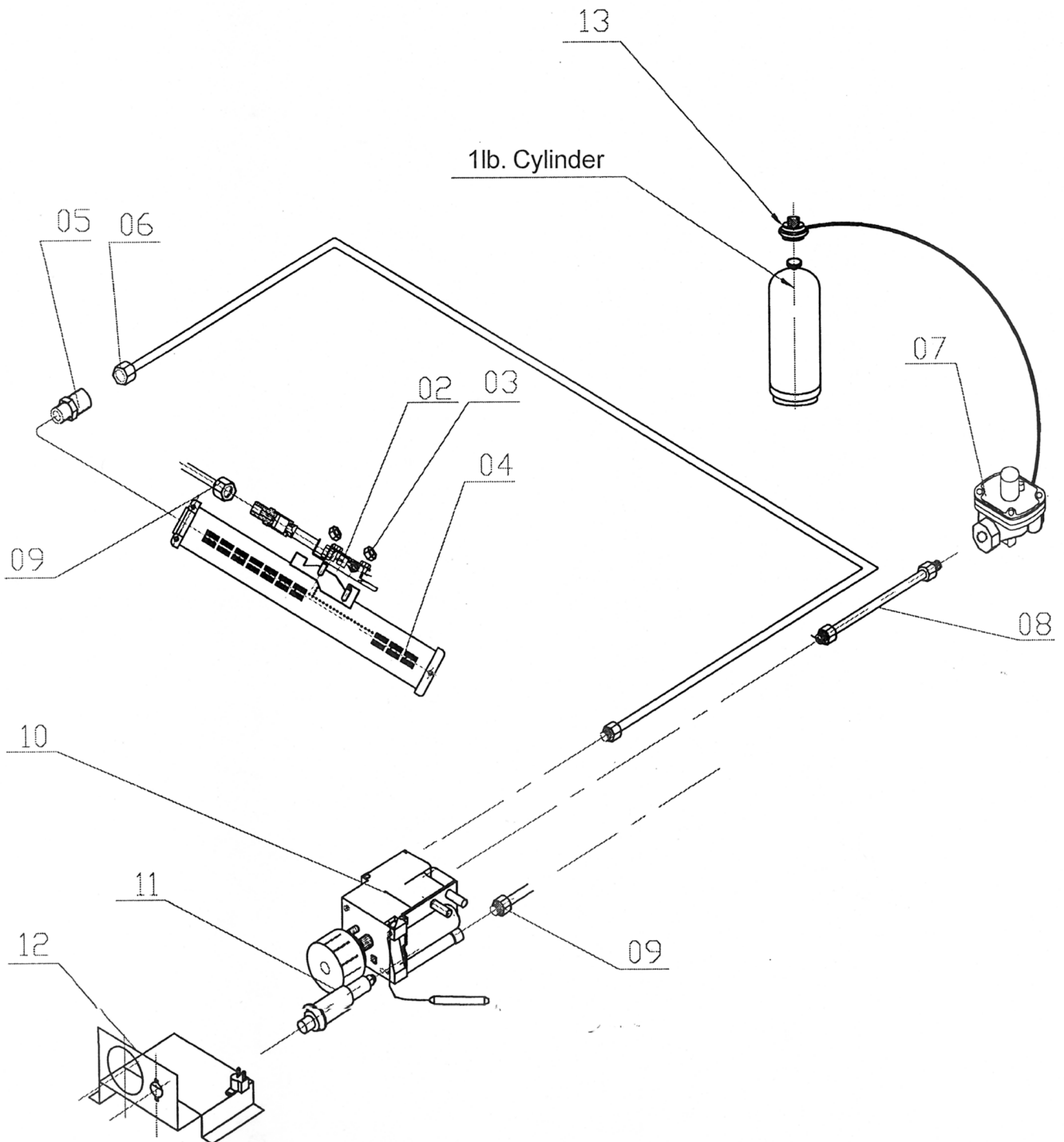
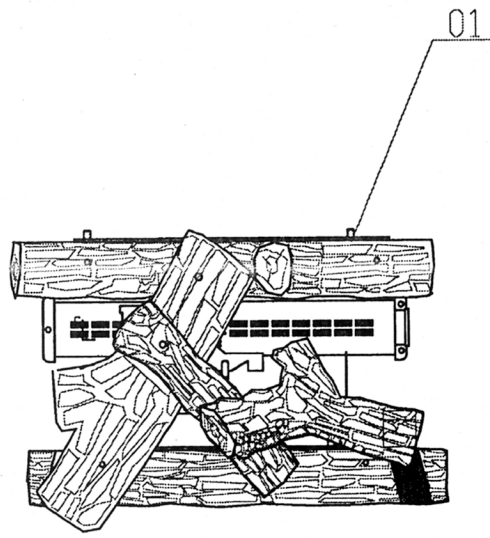

PARTS LIST
GSP1012

This list contains replaceable parts used in your heater. When ordering parts, follow the instructions listed under *Replacement Parts* on page 12 of this manual.

KEY NO	PART NUMBER	DESCRIPTION	QTY
			LP
01	EB33400	Decorating Logs Assembly	1
02	ND1808X400-A	ODS3010(LP)	1
03	6170-5Z	M5 Nut	2
04	NBY10-045E2	Burner(LP)	1
05	EL019-04	Injector(LP)	1
06	EB37400	Outlet Tube Assembly	1
07	NRV81F1-8	Regulator RV81FI8"(LP)	1
08	SB36400	Inlet Tube Assembly	1
09	EB38400	ODS Inlet Tube Assembly	1
10	SIT545-090	SIT Thermostat Control Valve 0630545	1
11	ML083-02	Ignitor	1
12	EL014-01	Thermostat Control Valve Bracket	1
13	NR12	Press Regulator	1
14	UG-7X	Tip-over Switch	1
	SCL029-01	Warning Plate	1
	SL030-01	Lighting Instruction Plate	1

**ILLUSTRATED
PARTS BREAKDOWN
GSP1012**

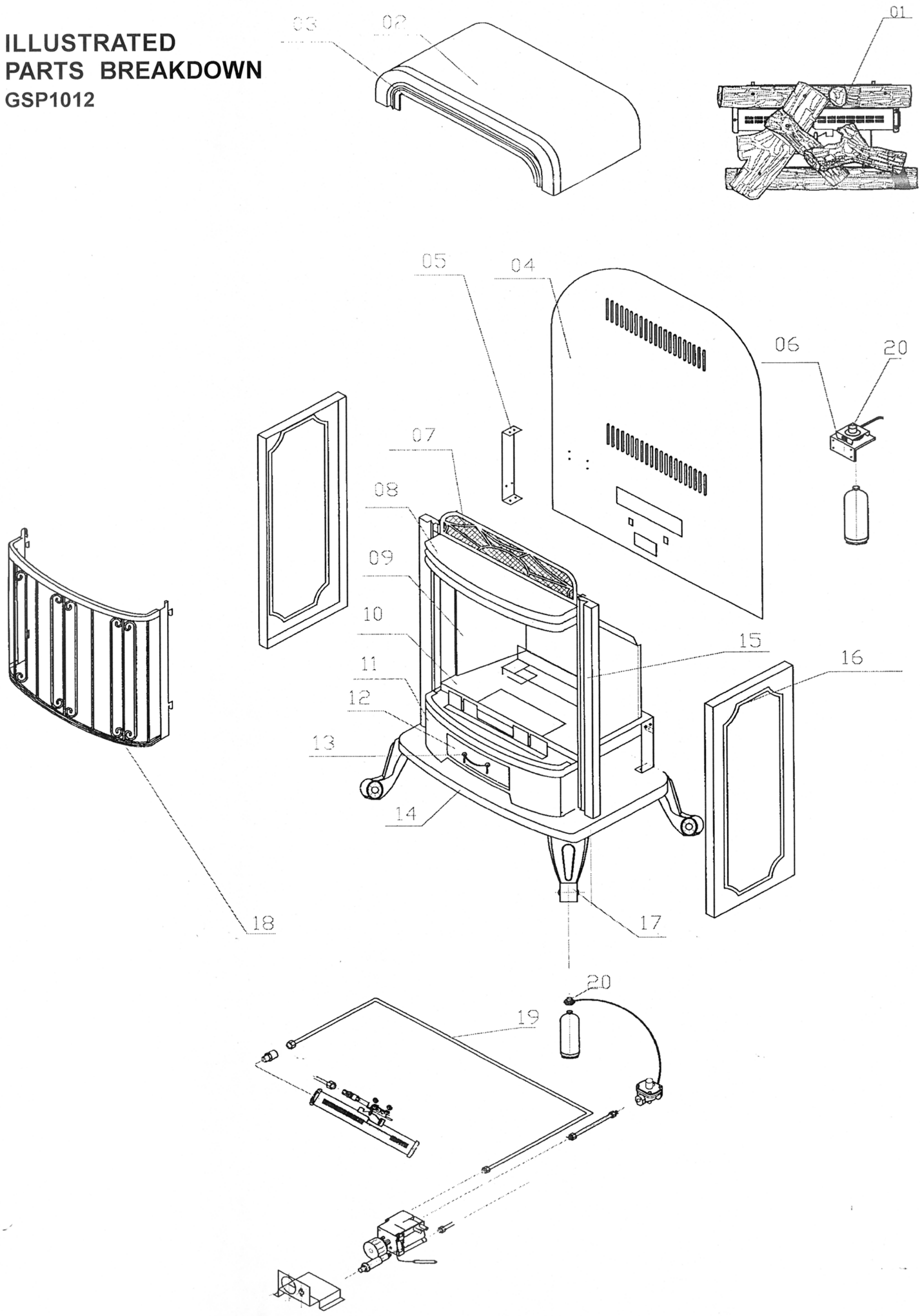

PARTS LIST
GSP1012

KEY NO	PART NUMBER	DESCRIPTION	QTY
			LP
1	EB33400	Decorating Logs Assembly	1
2	VL028-01	Top Panel	1
3	SL036-04	Decorating Frame	1
4	SCL031-05A	Back Panel	1
5	EL004-01	Regulator Bracket	1
6	SCL016-05A	Cylinder Fasten Frame	1
7	EL011-01	Upper Decorating Wire	1
8	SL002(03)-04	Upper (Mid) Louver	1
9	EB11000	Reflect Assembly	1
10	EL007-04	Firebox Floor Assembly	1
11	EL012-01	Lower Front Panel	1
12	EL013-01	Door	1
13	224	Knob Assembly	1
14	SCL025-05	Pedestal	1
15	SL037-04	Right(Left) Column	1
16	VL029-01	Right(Left) Side Panel	1
17	SL017-04A	Cast Iron Leg	1
18	EB29000	Grill	1
19		Burner Assembly	1
20	NR12	Press Regulator	1

SKETCH DRAWING OF LOG FIXED IN MOTHERBOARD OF BURNER CHAMBER

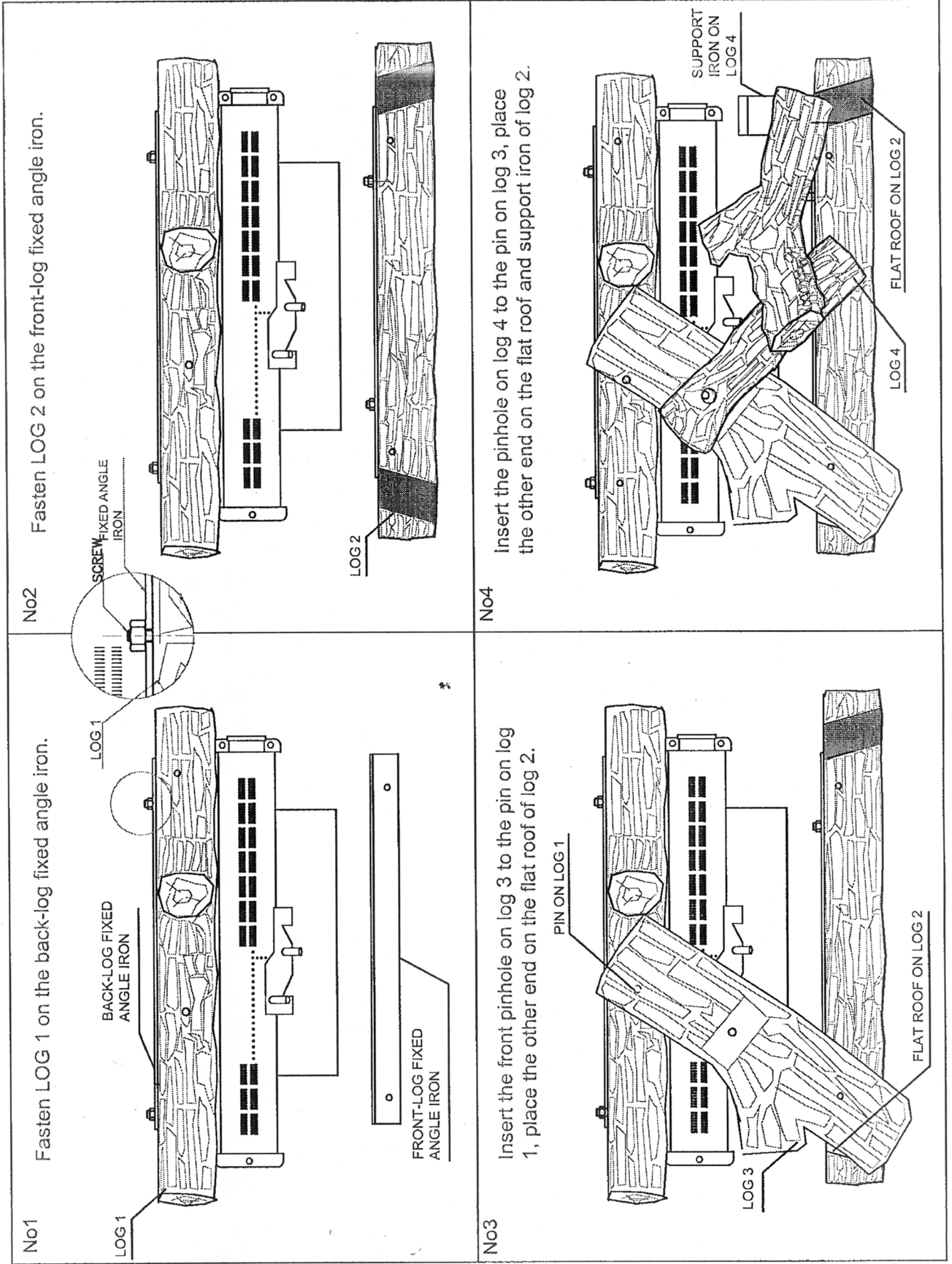

UNPACKING AND INSTALLING THE HEATER

1. Remove packing tape and adhesive tape. Take the upper carton and remove it. Carefully carry out the heater from the lower carton base (see Figure 1).

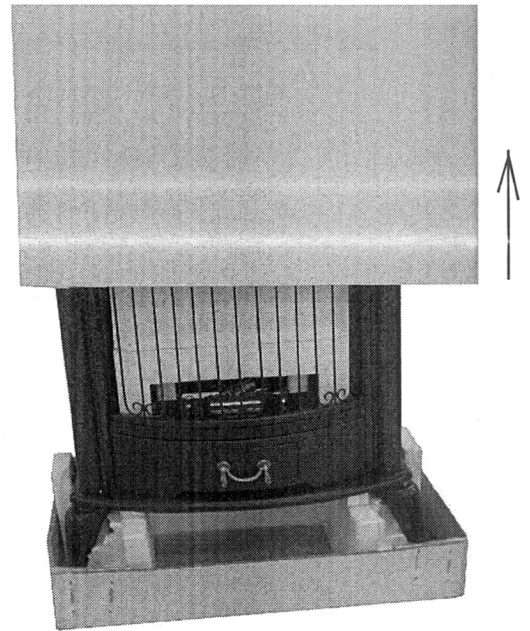

Figure 1

2. Remove screen and decorating logs package (The white foamed plastic bag).

- Remove two fixing self-tapping screws on the screen, pull the screen upward a little bit and then pull it out (see Figure 2).



Figure 2

- Take the white foamed plastic bag out. Be sure to take upper part of the bag out first (see Figure 3).



Figure 3

3. Install the decorating logs.

- Fasten decorating logs 1 and 2 onto the correspondent angle iron (Figure 5 and 6).



Figure 4



Figure 5



Figure 6

- Insert the pinhole on the upper part of log 3 into the pin on the left side of log 1. Place the lower part on the flat roof at the left side of log 2 (Figure 7).
- Insert the pinhole on the upper side of log 4 into the pin on the right side of log 1. Place the lower part on the flat roof at the right side of log 2 (Figure 8).



Figure 7



Figure 8

4. Install the heater according to the Installation in the owner's manual.