

Kozy-World®

COMPACT L.P. & NATURAL
GAS VENT-FREE STOVE

OWNER'S OPERATION AND INSTALLATION MANUAL

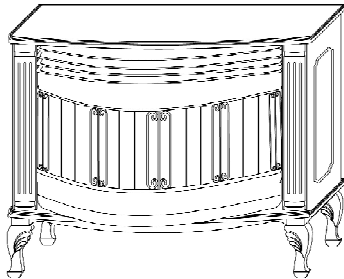

GSN3021R GSP3022R

⚠ WARNING: Improper installation, adjustment, alteration, service or maintenance can cause injury or property damage. Refer to this manual for correct installation and operational procedures. For assistance or additional information consult a qualified installer, service agency, or local gas supplier.

⚠ WARNING: This is an unvented gas-fired heater. It uses air (oxygen) from the room in which it is installed. Provisions for adequate combustion and ventilation air must be provided. Refer to Air For Combustion and Ventilation section on page 5 of this manual.



World-Marketing of
America, Inc.
P.O. Box 192, Rt. 22 West
Mill Creek, PA 17060

KOZY-WORLD PHONE NUMBER: (814) 643-1775

<http://www.worldmktng.com>

⚠ WARNING: If the information in this manual is not followed exactly, a fire or explosion may result causing property damage, personal injury, or loss of life.

Do not store or use gasoline or other flammable vapors and liquids in the vicinity of this or any other appliance.

WHAT TO DO IF YOU SMELL GAS

- Do not try to light any appliance.
- Do not touch any electrical switch; do not use any phone in your building.
- Immediately call your gas supplier from a neighbor's phone. Follow the gas supplier's instructions.
- If you cannot reach your gas supplier, call the fire department.

Installation and service must be performed by a qualified installer, service agency, or local gas supplier.

This appliance may be installed in an aftermarket*, permanently located manufactured (mobile) home, where not prohibited by local codes. This appliance is only for use with the type of gas indicated on the rating plate. This appliance is not convertible for use with other gases.

WATER VAPOR: A BY-PRODUCT OF UNVENTED ROOM HEATERS

Water vapor is a by-product of gas combustion. An unvented room heater produces approximately one (1) ounce (30) ml of water for every 1,000 BTU'S (.3 KW'S) of gas input per hour. Refer to page 7.

Consumer : Please retain these instructions for future use.

Installer: Please leave these instructions with the consumer.

*Aftermarket: Completion of sale, not for purpose of resale, from the manufacturer.

KW-QL058-04RW-0505

Table of Contents

Safety information warnings-----	3
Air for combustion & Ventilation-----	5
Installation-----	7
Operation Heater-----	11
Cleaning and Maintenance-----	14
Specification-----	16
Troubleshooting-----	17
Parts Breakdown & Parts List-----	19
Log Placing Instructions-----	23

SAFETY INFORMATION WARNINGS

IMPORTANT: Read this owner's manual carefully and completely before trying to assemble, operate, or service this heater. Improper use of this heater can cause serious injury or death from burns, fire, explosion, electrical shock, and carbon monoxide poisoning.

⚠ DANGER: Carbon monoxide poisoning may lead to death!

Carbon Monoxide Poisoning: Early signs of carbon monoxide poisoning resemble the flu, with headaches, dizziness, or nausea. If you have these signs, the heater may not be working properly. Get fresh air at once! Have heater serviced. Some people are more affected by carbon monoxide than others. These include pregnant women, people with heart or lung disease, anemia, those under the influence of alcohol, and those at high altitudes.

Propane/LP Gas: Propane/LP gas is odorless. An odor-making agent is added to Propane/LP gas. The odor helps you detect a Propane/LP gas leak. However, the odor added to Propane/LP gas can fade. Propane/LP gas may be present even though no odor exists.

Natural Gas: Natural gas is odorless. An odor-making agent is added to natural gas. The odor helps you detect a natural gas leak. However, the odor added to natural gas can fade. Natural gas may be present even though no odor exists. Make certain you read and understand all warnings. Keep this manual for reference. It is your guide to safe and proper operation of this heater.

⚠ WARNING: Any change to this fireplace or its controls can be dangerous.

WARNING
Model GSN3021R is equipped for natural gas. Field conversion is not permitted.
Model GSP3022R is equipped for propane gas. Field conversion is not permitted.

⚠ WARNING: Do not allow fans to blow directly into the heater. Avoid any drafts that alter burner flame patterns. Ceiling fans can create drafts that alter burner flame patterns. Altered burner patterns can cause sooting.

⚠ WARNING: Do not use a blower insert, heat exchanger insert, or other accessory not approved for use with this heater.

Due to high temperatures, the appliance should be located out of traffic and away from furniture and draperies.

Do not place clothing or other flammable material on or near the appliance. Never place any objects in the fireplace.

Heater becomes very hot when running fireplace. Keep children and adults away from hot surfaces to avoid burns or clothing ignition. Fireplace will remain hot for a time after shutoff. Allow surfaces to cool before touching.

Carefully supervise young children when they are in the room with the fireplace.

You must operate this heater with the heater screen in place. Make sure the heater screen is in place before running heater.

State of Massachusetts: The installation must be made by a licensed plumber or gas fitter in the Commonwealth of Massachusetts. Sellers of unvented propane or natural gas-fired supplemental room heaters shall provide to each purchaser a copy of 527 CMR 30 upon sale of the unit. In the state of Massachusetts, unvented propane or natural gas-fired space heaters shall be prohibited in bedrooms and bathrooms.

Keep the appliance area clear and free from combustible materials, gasoline, and other flammable vapors and liquids.

1. This appliance is only for use with the type of gas indicated on the rating plate. This appliance is not convertible for use with other gases.
2. Do not place Propane/LP supply tank(s) inside any structure. Locate Propane/LP supply tank(s) outdoors.
3. If you smell gas
 - Shut off gas supply.
 - Do not try to light any appliance.
 - Do not touch any electrical switch: do not use any phone in your building.
 - Immediately call your gas supplier from a neighbor's phone. Follow the gas supplier's instructions.
 - If you cannot reach your gas supplier, call the fire department.
4. This heater shall not be installed in a bedroom or bathroom.
5. Do not use this heater as a wood-burning heater. Use only the logs provided with the heater.
6. Do not add extra logs or ornaments such as pine cones, vermiculite, or rock wool. Using these added items can cause sooting. Do not add lava rock around base. Rock and debris could fall into the control area of heater. After servicing, always replace screen before operating heater.
7. You must operate this heater with the heater screen in place. Make sure heater screen is in place before running heater.
8. This heater is designed to be smokeless. If logs ever appear to smoke, turn heater off and call a qualified service person. Note: During initial operation, slight smoking could occur due to log curing and heater burning manufacturing residues.
9. To prevent the creation of soot, follow the instructions in *Cleaning and Maintenance*

SAFETY INFORMATION

Continued

10. Before using furniture polish, wax, carpet cleaner, or similar products, turn heater off. If heated, the vapors from these products may create a white powder residue within burner box or on adjacent walls or furniture.
11. This heater needs fresh air ventilation to run properly. This heater has an Oxygen Depletion Sensing (ODS) safety shutoff system. The ODS shuts down the heater if not enough fresh air is available. See *Air for Combustion and Ventilation*, pages 5 through 6. If heater keeps shutting off, see *Troubleshooting*, pages 16 through 17.
12. Do not run heater:
 - Where flammable liquids or vapors are used or stored.
 - Under dusty conditions.
13. Do not use this heater to cook food or burn paper or other objects.
14. Do not use heater if any part has been under water. Immediately call a qualified service technician to inspect the room heater and to replace any part of the control system and any gas control which has been under water.

15. Turn off and unplug heater and let cool before servicing. Only a qualified service person should service and repair heater.
16. Operating heater above elevations of 4,500 feet could cause pilot outage.
17. Do not operate heater if any log is broken. Do not operate heater if a log is chipped (dime-sized or larger).
18. To prevent performance problems, do not use Propane/LP fuel tank of less than 100 lbs. capacity.

PRODUCT FEATURES

SAFETY PILOT

This heater has a pilot with an Oxygen Depletion Sensing (ODS) safety shutoff system. The ODS/pilot is a required feature for vent-free room heaters. The ODS/pilot shuts off the heater if there is not enough fresh air.

Override control SYSTEM

This fireplace has two operation method: Remote Control and Overide Control. The Remote Control has a transmitter, which requires three AAA batteries and electric power outlet to operate. If no power, you can operate the fireplace by manual.

PRODUCT IDENTIFICATION

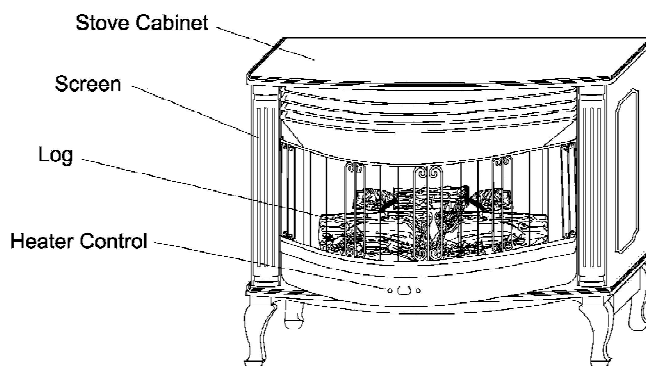

Figure 1- Vent Free LP/NG Gas Stove

LOCAL CODES

Install and use heater with care. Follow all local codes. In the absence of local codes, use the latest edition of The National Fuel Gas Code, ANSZ 223.1, also known as NFPA 54*.

*Available from:
American National Standards Institute, Inc.
1430 Broadway
New York, NY 10018
National Fire Protection Association, Inc.
Batterymarch Park
Quincy, MA 02269

This heater is designed for vent-free operation. State and local codes in some areas prohibit the use of vent-free heaters.

UNPACKING

1. Remove top inner pack.
2. Tilt carton so that stove is upright.
3. Remove protective side packaging.
4. Slide stove out of carton.
5. Remove protective plastic wrap.
6. Remove two self-tapping screws on the screen, then lift and pulling forward.
7. Remove log set by cutting plastic ties.
8. Carefully unwrap log.
9. Check for any shipping damage. If stove or log is damaged, promptly inform dealer where you bought stove.

AIR FOR COMBUSTION AND VENTILATION

⚠ WARNING: This heater shall not be installed in a confined space or unusually tight construction unless provisions are provided for adequate combustion and ventilation air. Read the following instructions to insure proper fresh air for this and other fuel-burning appliances in your home.

PROVIDING ADEQUATE VENTILATION

The following are excerpts from *National Fuel Gas Code, NFPA 54/ANSZ 223.1, Section 5.3, Air for Combustion and Ventilation*.

All spaces in homes fall into one of the three following ventilation classifications:

1. Unusually Tight Construction
2. Unconfined Space
3. Confined Space

The information on pages 5 through 6 will help you classify your space and provide adequate ventilation.

Confined and Unconfined Space

The National Fuel Gas Code, ANS Z223.1 defines a confined space as a space whose volume is less than 50 cubic feet per 1,000 Btu per hour (4.8 m³ per kw) of the aggregate input rating of all appliances installed in that space and an unconfined space as a space whose volume is not less than 50 cubic feet per 1,000 Btu per hour (4.8 m³ per kw) of the aggregate input rating of all appliances installed in that space. Rooms communicating directly with the space in which the appliances are installed*, through openings not furnished with doors, are considered a part of the unconfined space.

This heater shall not be installed in a confined space or unusually tight construction unless provisions are provided for adequate combustion and ventilation air.

* Adjoining rooms are communicating only if there are doorless passageways or ventilation grills between them.

Unusually Tight Construction

The air that leaks around doors and windows may provide enough fresh air for combustion and ventilation. However, in buildings of unusually tight construction, you must provide additional fresh air.

Unusually tight construction is defined as construction where:

- a) walls and ceilings exposed to the outside atmosphere have a continuous water vapor retarder with a rating of one perm (6×10^{-11} kg per pa-sec-m²) or less with openings gasketed or sealed and
- b) weather stripping has been added on openable windows and doors and
- c) caulking or sealants are applied to areas such as joints around window and door frames, between sole plates and floors, between wall-ceiling joints, between wall panels, at penetrations for plumbing, electrical, and gas lines, and at other openings.

If your home meets all of the three criteria above, you must provide additional fresh air. See *Ventilation Air From Outdoors*.

If your home does not meet all of the three criteria above, proceed to *Determining Fresh-Air Flow For Heater Location*.

DETERMINING FRESH-AIR FLOW FOR HEATER LOCATION

Determining if You Have a Confined or Unconfined Space

Use this worksheet to determine if you have a confined or unconfined space.

Space: Includes the room in which you will install heater plus any adjoining rooms with doorless passageways or ventilation grills between the rooms.

1. Determine the volume of the space (length×width×height).

Length×Width×Height=_____cu.ft. (volume of space)

Example: Space size 20ft. (length)×16ft.(width)×8ft. (ceiling height)=2560cu. ft. (volume of space)

If additional ventilation to adjoining room is supplied with grills or openings, add the volume of these rooms to the total volume of the space.

2. Divide the space volume by 50 cubic feet to determine the maximum Btu/Hr the space can support.

_____(volume of space)÷50 cu. ft.=(Maximum Btu/Hr the space can support)

Example: 2560 cu. ft. (volume of space)÷50 cu.ft.=51.2 or 51,200(maximum Btu/Hr the space can support)

3. Add the Btu/Hr of all fuel burning appliances in the space.

Vent-free heater	_____	Btu/Hr
Gas water heater*	_____	Btu/Hr
Gas furnace	_____	Btu/Hr
Vented gas heater	_____	Btu/Hr
Gas heater logs	_____	Btu/Hr
Other gas appliances* +	_____	Btu/Hr
Total	= _____	Btu/Hr

Example:

Gas water heater	30,000	Btu/Hr
Vent-free heater	+ 26,000	Btu/Hr
Total	= 56,000	Btu/Hr

*Do not include direct-vent gas appliances. Direct-vent draws combustion air from the outdoors and vents to the outdoors.

4. Compare the maximum Btu/Hr the space can support with the actual amount of Btu/Hr used.

_____ Btu/Hr (maximum the space can support)

_____ Btu/Hr (actual amount of Btu/Hr used)

Example : 51,200 Btu/Hr(maximum the space can support)
56,000 Btu/Hr(actual amount of Btu/Hr used)

The space in the above example is a confined space because the actual Btu/Hr used is more than the maximum Btu/Hr the space can support.

You must provide additional fresh air. Your options are as follows:

A. Rework worksheet, adding the space of an adjoining room. If the extra space provides an unconfined space, remove door to adjoining room or add ventilation grills between rooms. See *Ventilation Air From Inside Building*.

B. Vent room directly to the outdoors. See *Ventilation Air From Outdoors*.

C. Install a lower Btu/Hr heater, if lower Btu/Hr size makes room unconfined.

If the actual Btu/Hr used is less than the maximum Btu/Hr the space can support, the space is an unconfined space. You will need no additional fresh air ventilation.

WARNING: If the area in which the heater may be operated is smaller than that defined as an unconfined space or if the building is of unusually tight construction, provide adequate combustion and ventilation air by one of the methods described in the *National Fuel Gas Code, ANS Z223.1, Section 5.3* or applicable local codes.

Ventilation Air From Inside Building

This fresh air would come from an adjoining unconfined space. When ventilating to an adjoining unconfined space, you must provide two permanent openings: one within 12" of the ceiling and one within 12" of the floor on the wall connecting the two spaces (see options 1 and 2, Figure 2). You can also remove door into adjoining room (see option 3, Figure 2). Follow the *National Fuel Gas Code, NFPA 54/ANS Z223.1, Section 5.3, Air for Combustion and Ventilation* for required size of ventilation grills or ducts.

Ventilation Air From Outdoors

Provide extra fresh air by using ventilation grills or ducts. You must provide two permanent openings: one within 12" of the ceiling and one within 12" of the floor. Connect these items directly to the outdoors or spaces open to the outdoors. These spaces include attics and crawl spaces. Follow the *National Fuel Gas Code, NFPA 54/ANS Z223.1, Section 5.3, Air for Combustion and Ventilation* for required size of ventilation grills or ducts.

IMPORTANT: Do not provide openings for inlet or outlet air into attic if attic has a thermostat-controlled power vent. Heated air entering the attic will activate the power vent.

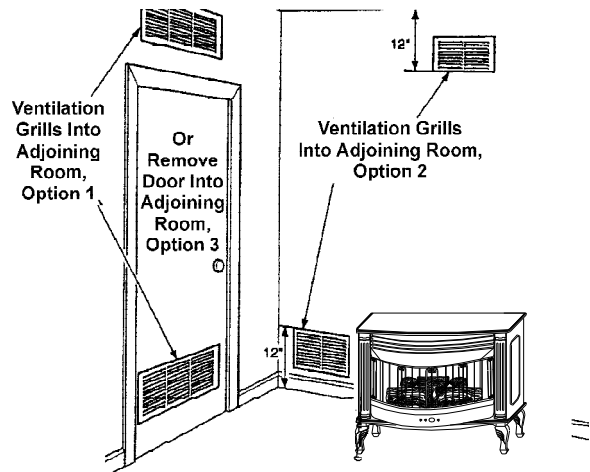

Figure 2 - Ventilation Air from Inside Building

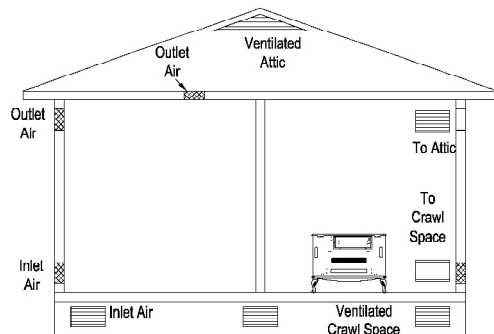

Figure 3 - Ventilation Air from Outdoors

WARNING: Rework worksheet, adding the space of the adjoining unconfined space. The combined spaces must have enough fresh air to supply all appliances in both spaces.

INSTALLATION

WATER VAPOR: A BY-PRODUCT OF UNVENTED ROOM HEATERS

Water vapor is by-product of gas combustion. An unvented room heater produces approximately one (1) ounce (30ml) of water for every 1,000 BTU's (.3kw's) of gas input per hour.

Unvented room heaters are recommended as supplemental heat (a room) rather than a primary heat source (an entire house) in most supplemental heat applications, the water vapor does not create a problem, in most applications the water vapor enhances the low humidity atmospheres experienced during cold weather.

The following steps will help insure that water vapor does not become a problem.

1. Be sure the heater is sized properly for the application, including ample combustion air and circulation of the air.
2. If high humidity is experienced, a dehumidifier may be used to help lower the water vapor content of the air.
3. Do not use an unvented room heater as the primary heat source.

WARNING: A qualified service person must install heater. Follow all local codes.

- WARNING:** Never install the heater
- in a bedroom or bathroom
 - in a recreational vehicle
 - where curtains, furniture, clothing, or other flammable objects are less than 42 inches from the front, top, or sides of the heater
 - in high traffic areas
 - in windy or drafty areas

WARNING: Maintain the minimum clearances. If you can, provide greater clearances from floor, ceiling, and adjoining side and back walls.

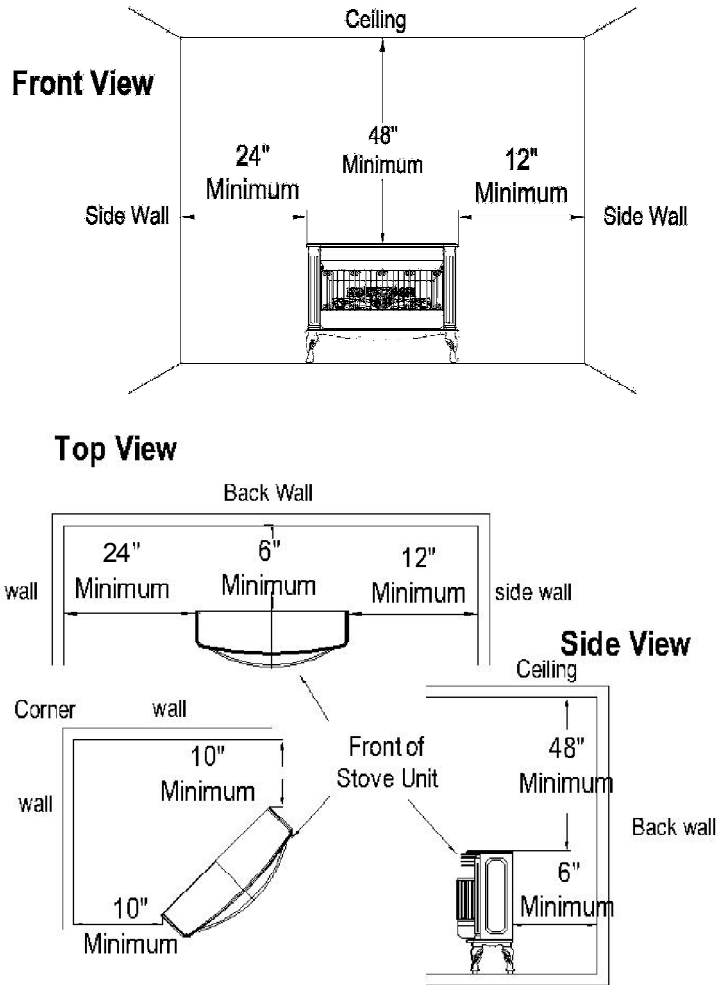

Figure 4 - Minimum Clearance to Wall and Ceiling

CAUTION: This heater creates warm air currents. These currents move heat to wall surfaces next to heater. Installing heater next to vinyl or cloth wall coverings or operating heater where impurities (such as tobacco smoke, aromatic candles, cleaning fluids, oil or kerosene lamps,

CHECK GAS TYPE

Be sure your gas supply is right for your heater. Otherwise, call dealer where you bought the heater for proper type heater.

IMPORTANT: Vent-free heaters add moisture to the air. Although this is beneficial, installing heater in rooms without enough ventilation air may cause mildew to form from too much moisture. See Air for Combustion and Ventilation, pages 5 through 6.

CLEARANCES TO COMBUSTIBLES

(Vent-Free Operation Only)

Carefully follow the instructions below. This stove is a freestanding unit designed to set directly on the floor.

IMPORTANT: You must maintain minimum wall and ceiling clearances during installation. The minimum clearances are shown in Figure 4. Measure from outermost point of stove top.

Minimum Wall and Ceiling Clearances (see Figure 4)

- Clearances from outermost point of stove top to any combustible side wall should not be less than 24 inches.
- Clearances from outermost point of stove top to any combustible back wall should not be less than 10 inches (Includes corner installations).
- Clearances from the stove top to the ceiling should not be less than 48 inches.

CONNECTING TO GAS SUPPLY

WARNING: A qualified service person must connect heater to gas supply. Follow all local codes.

CAUTION: Never connect heater directly to the gas supply. This heater requires an external regulator (not supplied). Install the external regulator between the heater and gas supply.

INSTALLATION ITEMS NEEDED

Before installing heater, make sure you have the items listed below.

- piping (check local codes)
- sealant (resistant to propane/LP gas)
- equipment shutoff valve*
- test gauge connection*
- sediment trap
- tee joint
- pipe wrench
- flexible gas hose. (check local codes)

*A CSA design-certified equipment shutoff valve with 1/8" NPT tap is an acceptable alternative to test gauge connection. Purchase the optional CSA design-certified equipment shutoff valve from your dealer. See Accessories.

The installer must supply an external regulator. The external regulator will reduce incoming gas pressure. You must reduce incoming gas pressure to rating inches of water. If you do not reduce incoming gas pressure, heater regulator damage could occur. Install external regulator with the vent pointing down as shown in Figure 6. Pointing the vent down protects it from freezing rain or sleet.

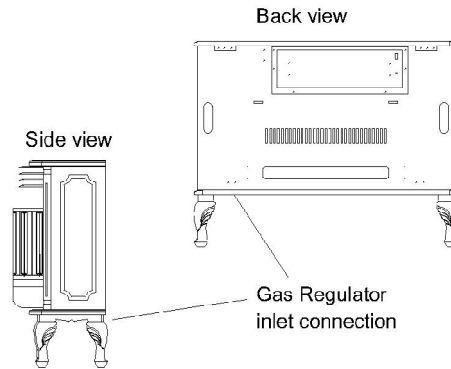

Figure 5 - Gas Regulator Location and Gas Line Access Into Stove Cabinet

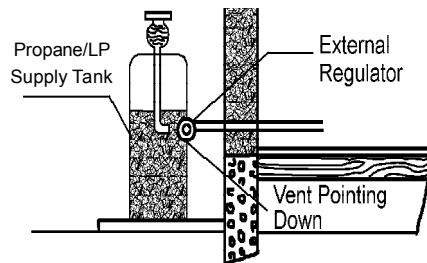

Figure 6 - External Regulator With Vent Pointing Down

NG Models:
5"-10.5" W.C.
Gas supplier provides external regulator for natural gas.

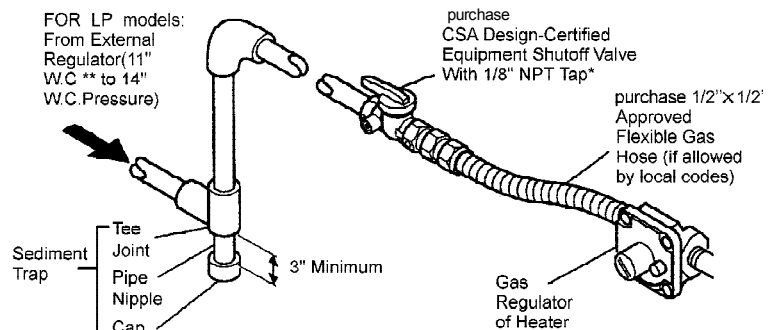

Figure 7 - Gas Connection

* Purchase the optional CSA design-certified equipment shutoff valve from your dealer. See Accessories.

** Minimum inlet pressure for purpose of input adjustment.

⚠ WARNING: Never connect heater to private (non-utility) gas wells. This gas is commonly known as wellhead gas.

⚠ CAUTION: Use only new, black iron or steel pipe. Internally-tinned copper tubing may be used in certain areas. Check your local codes. Use pipe of 1/2" diameter or greater to allow proper volume gas to heater. If pipe is too small, undue loss of pressure will occur.

Installation must include an equipment shutoff valve, union, and plugged 1/8" NPT tap. Locate NPT tap within reach for test gauge hook up. NPT tap must be upstream from heater (see Figure 7).

IMPORTANT: Install equipment shutoff valve in an accessible location. The equipment shutoff valve is for turning on or shutting off the gas to the appliance. Apply pipe joint sealant lightly to male threads. This will prevent excess sealant from going into pipe. Excess sealant in pipe could result in clogged heater valves.

⚠ CAUTION: Use pipe joint sealant that is resistant to gas (PROPANE or NG).

We recommend that you install a sediment trap in supply line as shown in Figure 7. Locate sediment trap where it is within reach for cleaning. Install in piping system between fuel supply and heater. Locate sediment trap where trapped matter is not likely to freeze. A sediment trap traps moisture and contaminants. This keeps them from going into heater controls. If sediment trap is not installed or is installed incorrectly, heater may not run properly.

⚠ WARNING: Do not over tighten gas connections.

⚠ CAUTION: Avoid damage to regulator. Hold gas regulator with wrench when connecting into gas piping and/or fittings.

CHECKING GAS CONNECTIONS

⚠ WARNING: Test all gas piping and connections for leaks after installing or servicing. Correct all leaks at once.

⚠ WARNING: Never use an open flame to check for a leak. Apply a mixture of liquid soap and water to all joints. Bubbles forming show a leak. Correct all leaks at once.

⚠ CAUTION: Make sure external regulator has been installed between gas supply and heater. See guidelines under Connecting to Gas Supply.

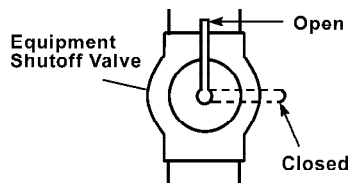

Figure 8 - Equipment Shutoff Valve

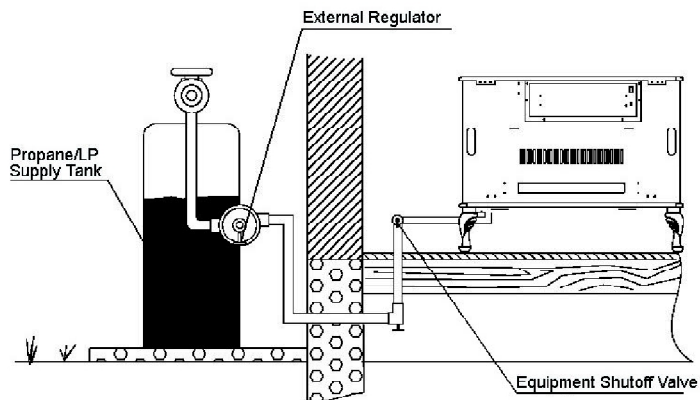

Figure 9.1 - Checking Gas Joints

Pressure Testing Gas Supply Piping System

Test Pressures In Excess Of 1/2 PSIG(3.5kPa)

1. Disconnect heater with its appliance main gas valve (control valve) and equipment shutoff valve from gas supply piping system. Pressures in excess of 1/2 PSIG will damage heater regulator.
2. Cap off open end of gas pipe where equipment shutoff valve was connected.
3. Pressurize supply piping system by either using compressed air or opening gas supply tank valve.
4. Check all joints of gas supply piping system. Apply mixture of liquid soap and water to gas joints. Bubbles forming show a leak.
5. Correct all leaks at once.
6. Reconnect heater and equipment shutoff valve to gas supply. Check reconnected fittings for leaks.

Pressure Testing Heater Gas Connections

1. Open equipment shutoff valve (see Figure 8).

2. Open gas supply tank valve.
3. Make sure control knob of heater is in the OFF position.
4. Check all joints from equipment shutoff valve to control valve (LP GAS see Figure 9.1 NATURAL GAS see Figure 9.2). Apply mixture of liquid soap and water to gas joints. Bubbles forming show a leak.
5. Correct all leaks at once.
6. Light heater (see Operating Heater). Check all other internal joints for leaks.
7. Turn off heater (see To Turn Off Gas Appliance).

⚠ WARNING: Failure to position the parts in accordance with these diagrams or failure to use only parts specifically approved with this heater may result in property damage or personal injury.

⚠ CAUTION: After installation and periodically thereafter, check to ensure that no flame comes in contact with any log. With the heater set to High, check to see if flames contact any log. If so, reposition logs according to the log installation instructions in this manual. Flames contacting logs will create soot.

It is very important to install the logs exactly as instructed. Do not modify logs. Only use logs supplied with heater.

Place log set on grate to fit as illustrated in Figure 10. Make sure log sits flat on firebox floor (see Figure 10).

IMPORTANT: Make sure log does not cover any burner ports (see Figure 11).

Also, see log placing instructions.

Test Pressures Equal To or Less Than 1/2 PSIG(3.5 kPa)

1. Close equipment shutoff valve (see Figure 8).
2. Pressurize supply piping system by either using compressed air or opening natural supply tank valve.
3. Check all joints from gas meter to equipment shutoff valve(see Figure 9). Apply mixture of liquid soap and water to gas joints. Bubbles forming show a leak.
4. Correct all leaks at once.

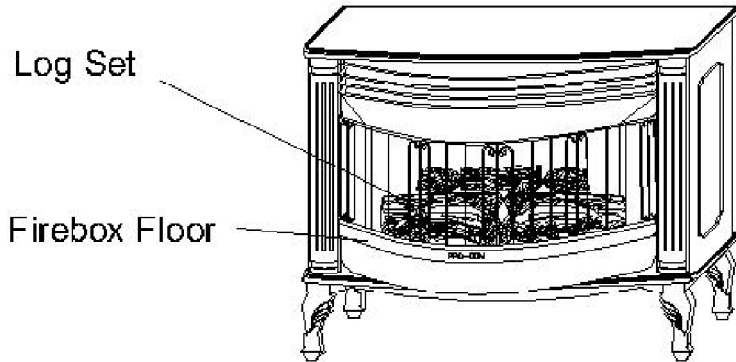

Figure 10-Installing Log Set

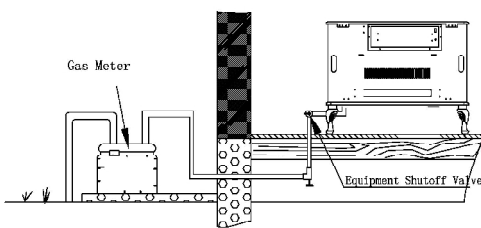

Figure 9.2-Checking Gas Joints

Figure 9.2-Checking Gas Joints

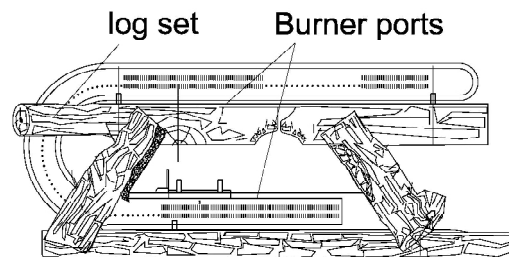

Figure 11-Installing Log Set (Top View)

**OPERATING HEATER
FOR YOUR SAFETY
READ BEFORE LIGHTING**

⚠ WARNING: If you do not follow these instructions exactly, a fire or explosion may result causing property damage, personal injury or loss of life.

- A. This appliance has a pilot which must be lighted by control system, When lighting the pilot, follow these instructions exactly.
- B. BEFORE LIGHTING smell all around the appliance area for gas. Be sure to smell next to the floor because some gas is heavier than air and will settle on the floor.

WHAT TO DO IF YOU SMELL GAS
SEE WARNING in Page 1 for proper instructions.

C. Use only your hand to push in control knob. Never use tools. If the the appliance could not operate, don't try to repair it, Call a qualified service technician or gas supplier. Forced or attempted re-pair may result in a fire or explosion.

D. Do not use this appliance if any part has been under water. Immediately call a qualified service technician to inspect the appliance and to replace any part of the control system and any gas control which has been under water.

**TO TURN OFF GAS TO APPLIANCE
Shut off heater**

- 1. Press the IGN/OFF button of transmitter.
- 2. Set the Switch on OFF location. (See Figure 11-2)

Shutting off burner only (pilot stay lit)

- 1. press the BURNER to set flame OFF select

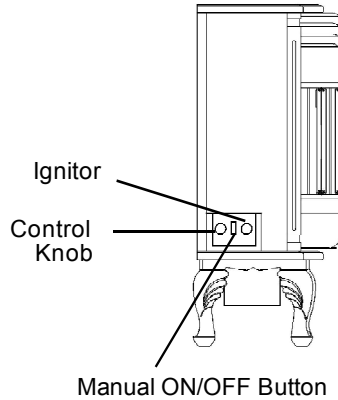

Figure 12-1 Manual ON/OFF Button location

Function of Manual ON/OFF Button and ON/OFF Switch

If your remote transmitter is lost or does not function, you can press the Manual ON/OFF Button in order to manually operate your heater. To operate your heater the ON/OFF switch must be in the ON position. The RED light indicates there is electrical power to your heater when the ON/OFF switch is in the ON position. The GREEN light indicates the pilot light is ON.

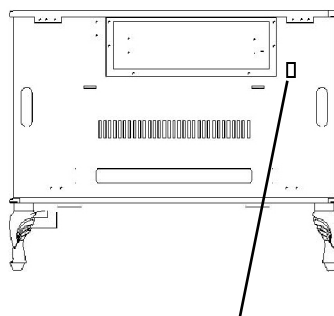

Figure 12-2 On/Off Switch

**OPERATING INSTRUTION OF
REMOTE-CONTROL**

**OPERATIONS OF
LIGHTING**

NOTE: Make sure the manual control knob in the electric position. Do not set the control knob between the locked position, otherwise there will be no power to the heater. (See figure 17)

- 1. STOP! Read the safety information, page 2.
- 2. Make sure equipment shutoff valve is fully open.
- 3. Press in and rotate control knob clockwise to Electric position and ON/OFF switch is in the ON position.

⚠ NOTICE: During initial operation of new fireplace, burning logs will give off a paper-burning smell. Orange flame will also be present. Open a window to vent smell. This will only last a few hours.

⚠ CAUTION: Do not try to adjust heating levels by using the equipment shutoff valve.

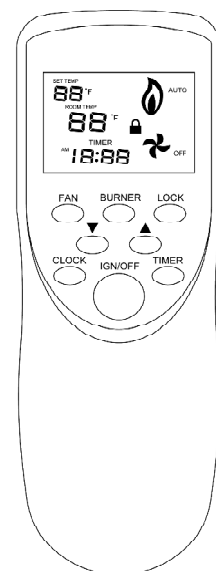

Fig 13 Front of the Transmitter

OPERATING HEATER *Continued*

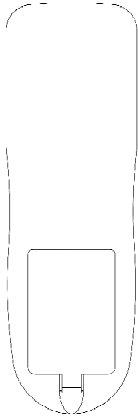

Fig 14 Back of the Transmitter

■ OPERATIONS OF ■ REMOTE TRANSMITTER

1. Install three AAA SIZE batteries in the battery holder.

The initial start-up on the LCD is: SET TEMP is 77°F, ROOM TEMP is 77°F, clock is AM12:00, burner is on "OFF" select, and fan is on "AUTO" select. Divide Points of hour and minute are flashing (i.e. the timer is operating).

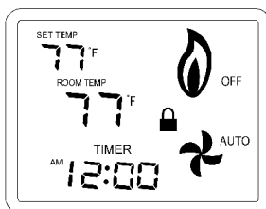

Fig 15 Initial start-up on the LCD

2. Clock setting: Press CLOCK button on the remote transmitter panel to select item (hour, minute). The selected item is flashing. Press ▲ or ▼ to change to the correct actual hour(s); Press ▲ or ▼ to change to the correct minute(s), then press CLOCK button again, time setting is finished.

3. When in operation, point the remote transmitter to the remote receiver on the burner in a maximum distance of 20 feet without any obstruction between them.

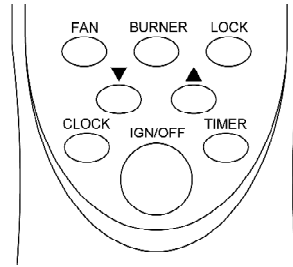

Fig16 Control board

■ OPERATIONS OF ■ BURNER

1. Plug-in 110V electrical outlet, you will hear a high pitch sound and power light (red) on the front will be lit that indicates that the burner is ready to be operated. Before plugging in the outlet make sure that the appliance is connected to the gas supply, then continue to the next step.

2. Point directly the remote transmitter to the burner. Press IGN/OFF button, the electric spark starts igniting the pilot and operation light (green) on the front will be lit. Wait five (5) minutes to clear out any air. If you smell gas. STOP! Please check the gas connection.

There are three selections: "AUTO" "MAN" and "OFF"

a. auto select of main burner:

Press BURNER button, the flame is on "AUTO" select. Press ▲ or ▼ to set temperature. If the room temperature is two degree lower than the set temperature on the remote, the main burner will turn on until the surrounding temperature is two degree higher than the set temperature. Once it reaches temperature on the remote, the main burner will automatically shut off.

(Note: on the auto select of main burner, the main burner does not respond immediately to the set temperature until about one minute later.)

b. manual select of main

burner:

Press BURNER button, the flame is on "MAN" select. At this selection, the main burner will keep working no matter what the temperature is set at. If there is a need to shut off the main burner, just press the "BURNER" button to make the burner on the "OFF" select.

c. shut off the main burner:

the main burner is on "OFF" selection. The main burner will shut off.

NOTE: The thermostat sensing bulb measures the temperature of air near the heater cabinet. This may not always agree with room temperature (depending on housing construction, installation location, room size, open air temperatures, etc.) Frequent use of your heater will let you determine your own comfort levels.

■ OPERATIONS OF ■ TIMING

1. Auto on:

when the burner is in a state of readiness. Transmitter and burner is off. Press TIMER button. Then press ▲ or ▼ change to the scheduled time, then press the TIMER button again, the TIMER starts timing and the TIMER is flashing and the operation light (green) begin flashing. When the timer goes on the scheduled time, the burner opens automatically.

2. Auto off:

when the burner is in operation, press TIMER button. Then press ▲ or ▼ to change to the scheduled time, then press the TIMER button again, the TIMER starts timing and the TIMER is flashing and the operation light begin flashing. When the timer goes on the scheduled time, the burner closes automatically. (See Fig 14)

■ OPERATIONS OF ■ TURN-OFF

1. Manual turn-off: when the heater is in operation, press the IGN/OFF button to shut off the heater.

2. Auto turn-off: refer to the second step of "Operations of Timing"

3. After completion of the above-mentioned two steps, the transmitter is kept in a state of readiness. If the appliance doesn't working for a period time, just pull out the plug from the 110V electrical outlet.

■ OPERATIONS OF ■ KEY-PRESS LOCKING

1. Key press locking:

when the burner is in operation or the transmitter is in a state of readiness, just press LOCK button on the operating

panel, there will be a "🔒" symbol on the LCD. If any button is pressed now, the burner will not react at all.

2. Key-press unlocking:

when the burner is in a state of key-press locking, first press ▼, then press LOCK button to unlock it (Child proof-See Fig17)

■ OPERATIONS OF ■ FAN

There are three selections: "AUTO" "MAN" and "OFF". When pushing the "FAN" button on the "AUTO" select, the fan will be controlled by the thermostat on the fan blower unit. On the "MAN" select, the fan will be kept in operation. To stop the operation, push the "FAN" button to "OFF" select. (See Fig17)

Manual Control System

We provide the manual control system just in case of power shortage.

Install battery for Manual Ignitor:

1. Unscrew the ignitor cap.
2. Insert a AAA type battery with its anode ("+") pointing out.
3. Screw the ignitor back.

Note: We recommend that the battery be taken out of the ignitor when the power supply gets right.

LIGHTING INSTRUCTIONS

1. STOP! Read the safety information on the plate with heater.
2. Check that gas supply to heater is on.
3. Open the door on the left side.
4. Push in gas control knob slightly and turn clockwise ↻ to the OFF position. If control knob in Electric position, press down and turn counterclockwise ↺ to OFF position, then release the knob.

NOTE: Knob cannot be turned from "PILOT" to "OFF" unless knob is pushed in slightly. Do not force.

5. Wait five (5) minutes to clear out any air. then smell for gas including near the floor. If you smell gas, STOP! Follow "B" in the safety information on the side of the heater. If you do not smell gas, go to the next step.
6. Push in gas control slightly and turn counterclockwise ↺ to "PILOT/IGN" and depress for five (5) seconds.

NOTE: The first time that the heater is operated after connecting the gas supply, the control knob should be depressed for about thirty(30) seconds. This will allow air to bleed from the gas system.

7. With control knob pressed in, push down and release the ignitor button. This will light pilot. If needed, keep pressing ignitor button until pilot lights.
8. Keep control knob depressed for ten(10) seconds after lighting pilot. If pilot goes out, repeat steps 5, 6 and 7.
9. To turn on main burner, partially press down the control knob slightly and rotate counterclockwise ↺. Release the downward pressure on the knob while continuing to turn until the knob locks at the "ON" position. Do not operate between locked positions.

TO TURN OFF GAS TO APPLIANCE

Shutting Off Heater

1. Turn control knob clockwise ↻ to the OFF position.
2. **Shutting off Burner Only (pilot stays lit)**
Turn control knob clockwise ↻ to the PILOT position.

MANUAL LIGHTING PROCEDURE

1. Follow steps 1 through 5 under *Lighting Instructions*.
2. With control knob pressed in, strike match. Hold match to pilot until lights.
3. Keep control knob pressed in for 30 seconds after lighting pilot. After 30 seconds, release control knob. Follow step 8 under *Lighting Instruction*.
4. Replace lower front panel.

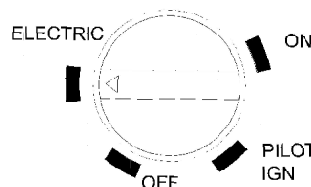

Figure 17-Manual Control

INSPECTING BURNERS

Check pilot flame pattern and burner flame patterns often.

PILOT FLAME PATTERN

Figure 18 shows a correct pilot flame pattern. Figure 19 shows an incorrect pilot flame pattern. The incorrect pilot flame is not touching the thermocouple. This will cause the thermocouple to cool. When the thermocouple cools, the heater will shut down. If pilot flame pattern is incorrect, as shown in Figure 19.

- Turn heater off (see TO TURN OFF GAS TO APPLIANCE)
- see *troubleshooting*

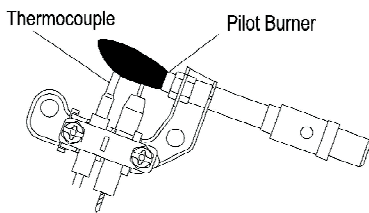

Figure 18 -Correct Pilot Flame Pattern

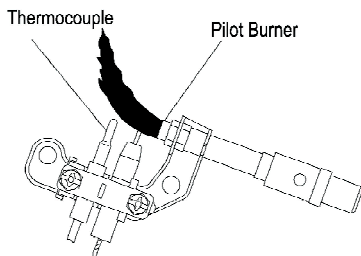

Figure 19 -Incorrect Pilot Flame Pattern

BURNER FLAME PATTERN

Figure 20 shows a correct burner flame pattern. Figure 21 shows an incorrect burner flame pattern. If burner flame is incorrect:

- Turn heater off (see TO TURN OFF GAS TO APPLIANCE)
- See *troubleshooting*



Figure 20-Correct Flame Pattern with Control Knob Set to High Flame

Move Than 8"
Above Top of logs



Figure 21 -Incorrect Flame Pattern with Control Knob Set to High Flame

CLEANING AND MAINTENANCE

WARNING: Disconnect power before attempting any maintenance or cleaning to reduce the risk of fire, electric shock or personal injury. Turn off heater and let cool before cleaning.

CAUTION: Label all wires prior to disconnection when servicing controls. Wiring errors can cause improper and dangerous operation. Verify proper operation after servicing.

DISCONNECT WIRING OR CONTROL MODULE

1. Remove screws from the rear control panel, take out thermostat

sensing bulb from the clip, then disconnect the wires to free to control module from its mounting location. Note: Do not confuse the mark on the each wire.

2. Remove two screws and hex nuts, take out the control module. When installing, reverse the steps above. (See Figure 22 and Figure 26)

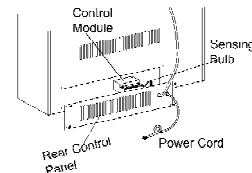

Figure 22- Control Model

DISCONNECT FAN

1. Remove screws from the fan bracket panel, pull the fan bracket panel out to remove. Then disconnect two wires free to fan.
2. Mark or tag each wire removed for its exact reconnection. Remove the four screws from the fan. When installing, reverse the steps above. (See Figure 23 and Figure 26)

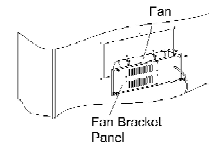

Figure 23- Fan

CAUTION: You must keep control areas, burner, and circulating air passageways of heater clean. Inspect these areas of heater before each use. Have heater inspected yearly by a qualified service person. Heater may need more frequent cleaning due to excessive lint from carpeting, bedding material, pet hair, etc.

The primary air inlet holes allow the proper amount of air to mix with the gas. This provides a clean burning flame. Keep these holes clear of dust, dirt, lint, and pet hair. Clean these air inlet holes prior to each heating season. Blocked air holes will create soot. We recommend that you clean the unit every three months during operation and have heater inspected yearly by a qualified service person.

We also recommend that you keep the burner tube and pilot assembly clean and free of dust and dirt. To clean these parts we recommend using compressed air no greater than 30 PSI. Your local computer store, hardware store, or home center may carry compressed air in a can. You can use a vacuum cleaner in the blow position. If using compressed air in a can, please follow the directions on the can. If you don't follow directions on the can, you could damage the pilot assembly.

1. Shut off the unit, including the pilot. Allow the unit to cool for at least thirty minutes.
2. Inspect burner, pilot and primary air inlet holes on injector holder for dust and dirt (See Figure 24).
3. Blow air through the ports/slots and holes in the burner.
4. Check the injector holder located at the end of the burner tube again. Remove any large particles of dust, dirt, lint, or pet hair with a soft cloth or vacuum cleaner nozzle.
5. Blow air into the primary air holes on the injector holder.
6. In case any large clumps of dust have now been pushed into the burner repeat steps 3 and 4.

Clean the pilot assembly also. A yellow tip on the pilot flame indicates dust and dirt in the pilot assembly. There is a small pilot air inlet hole about two inches from where the pilot flame comes out of the pilot assembly (see Figure 25). With the unit off, lightly blow air through the air inlet hole. You may blow through a drinking straw if compressed air is not available.

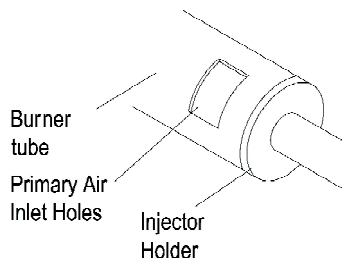

Figure 24-Injector Holder on Outlet Burner Tube

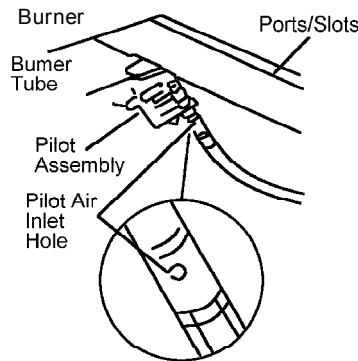

Figure 25-Pilot Inlet Air Hole

MAIN BURNER

Periodically inspect all burner flame holes with the heater running. All slotted burner flame holes should be open with yellow flame present. All round burner flame holes should be open with a small blue flame present. Some burner flame holes may become blocked by debris or rust, with no flame present. If so, turn off heater and let cool. Either remove blockage or replace burner. Blocked burner flame holes will create soot.

CABINET

Air Passageways

- Use a vacuum cleaner or pressurized air to clean.

Exterior

- Use a soft cloth dampened with a mild soap and water mixture. Wipe the cabinet to remove dust.

LOGS

- If you remove logs for cleaning, refer to Installing Logs to properly replace logs.
- Replace logs if broken or chipped (dimesized or larger).

REPLACEMENT PARTS NOTE:

Use only original replacement parts. This will protect your warranty coverage for parts replaced under warranty.

PARTS UNDER WARRANTY

Contact authorized dealers of this product. If they can't supply original replacement part(s) call the number on the back of manual. when contacting your dealer or Kozy-World, have ready:

- Your name
- Your address
- Model and serial numbers of your heater
- How heater was malfunctioning
- Type of gas used (propane/LP or NG)

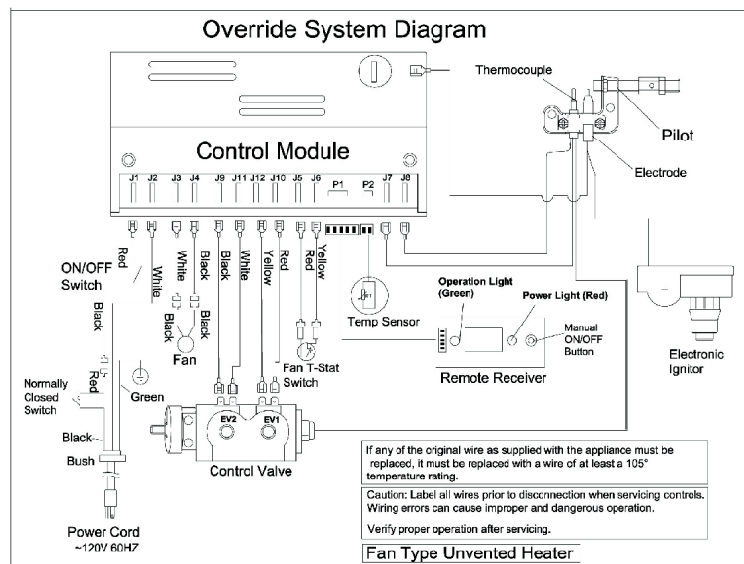

Figure 26-Override Control System Diagram

- Purchase date
- Usually, we will ask you to return the defective part to the factory.
- Warranty card.

PARTS NOT UNDER WARRANTY

Contact authorized dealers of this product or Parts Central. If they can't supply original replacement part(s) call Kozy-World's number on the front page.

ACCESSORIES

Purchase these heater accessories from your local dealer or Parts Central. This part is not currently available from Kozy-World.

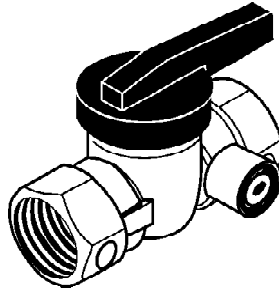

EQUIPMENT SHUTOFF VALVE-

Equipment shutoff valve with 1/8" NPT tap.

FLEXIBLE HOSE

Flexibe gas hose is used for connecting the heater to gas supply. the flex hose must approved by CSA .

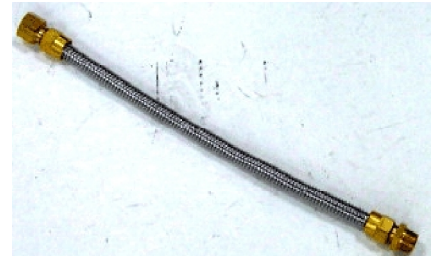

SPECIFICATIONS

GSP3022R

GSN3021R

Btu(Variable)		
Gas Type	LP Gas	Natural Gas
Ignition	Automatic or Electronic	Automatic or Electronic
Manifold Pressure	8"W.C.	3"W.C.
Inlet Gas Pressure (In. of water)*		
Maximum	14"	10.5"
Minimum	11"	5"
Dimensions, Inches (H×W×D)		
Heater	25 4/5"×32 1/4" ×13"	25 4/5"×32 1/4" ×13"
Carton	25 1/8"×34 1/8" ×12 7/8"	25 1/8"×34 1/8" ×12 7/8"
Weight, lbs		
Stove	74	74
Shipping	83	83
voltage	120	120
watt	32	32

*For purposes of input adjustment

TROUBLESHOOTING

NOTE: BEFORE YOU SWITCH TO "ELECTRIC" CONTROL LEVEL FROM MANUAL CONTROL, YOU NEED TO TURN THE KNOB TO "OFF" LEVEL FIRST AND WAIT FOR ONE MINUTE, THEN TURN THE KNOB TO "ELECTRIC". IN CASE OF "ELECTRONIC" CONTROL LEVEL DOES NOT WORK, PLEASE TURN THE CONTROL KNOB COUNTERCLOCKWISE TO "OFF" LEVEL AND WAIT FOR ONE MINUTE.

⚠ WARNING: Make sure that power is turn off before proceeding....

⚠ WARNING: Turn off and let cool before servicing. Only a qualified service person should service and repair fireplace.

⚠ CAUTION: Never use a wire, needle, or similar object to clean ODS/pilot. This can damage ODS/pilot unit.

OBSERVED PROBLEM	POSSIBLE CAUSE	REMEDY
No spark when press in ignition button	<ol style="list-style-type: none"> 1. No power to heater 2. No battery in transmitter or battery isn't correctly assembly 3. Control knob isn't in Electric position. 4. System halt 	<ol style="list-style-type: none"> 1. Check the electric power 2. Place or replace the battery. 3. Set control knob in Electric position. 4. Place the control knob of manual override on OFF position for at least 1 minute, then turn to ELECTRIC position
When pressing the button of ignitor button is pressed, there is spark at ODS/pilot but no ignition	<ol style="list-style-type: none"> 1. Gas supply turned off or equipment shut off valve closed 2. Air in gas lines when installed. 3. Depleted gas supply 4. ODS/pilot is clogged 5. Gas regulator setting is not correct 6. Pilot electrode position is not correct 7. Wire is not correct or loosen 8 Gas valve is damage 	<ol style="list-style-type: none"> 1. Turn on gas supply or open equipment shutoff valve 2. Press ON/OFF button again until air is removed. 3. Contact local propane/LP gas company 4 Clean ODS/pilot (see <i>Cleaning and Maintenance</i>, page 14) or replace ODS/pilot assembly 5. Replace gas control 6. Replace Pilot 7. Check the wire and make wire correct. 8. Replace gas valve
ODS/pilot lights but flame is continuous igniting and the main burner couldn't be lit.	<ol style="list-style-type: none"> 1. Thermocouple connection loose at control board 2. Pilot flame not touching thermocouple which allows thermocouple to cool, causing pilot flame to go out. This problem could be caused by one or both of the following <ol style="list-style-type: none"> A) Low gas pressure B) Dirty or partially clogged ODS/pilot 3. Thermocouple damaged 4. Control valve damaged 	<ol style="list-style-type: none"> 1. Hand tighten until snug, then tighten 1/4 turn more. 2. A) Contact local propane/LP gas company. B) Clean ODS/pilot (see <i>Cleaning and Maintenance</i>, page 14) or replace ODS/pilot assembly 3. Replace thermocouple 4. Replace control valve
Burner does not light after ODS/pilot is lit	<ol style="list-style-type: none"> 1. Burner orifice clogged 2. Inlet gas pressure is too low 3. Burner orifice diameter is too small 4. Thermocouple leads disconnected or improperly connected 5. Burners will not come in remote position 	<ol style="list-style-type: none"> 1. Clean burner (see <i>Cleaning and Maintenance</i>, page 14) or replace burner orifice. 2. Contact local propane/LP gas company 3. Replace burner orifice 4. Reconnect leads (see <i>wiring diagram</i>) 5. Replace battery in transmitter and receiver

TROUBLESHOOTING

Continued

OBSERVED PROBLEM	POSSIBLE CAUSE	REMEDY
Delayed ignition burner	<ol style="list-style-type: none"> 1. Manifold pressure is too low 2. Burner orifice clogged 	<ol style="list-style-type: none"> 1. Contact local gas company 2. Clean burner (see <i>Cleaning and Maintenance</i>, page 14)
Burner backfiring during combustion	<ol style="list-style-type: none"> 1. Damaged burner 2. Gas regulator defective 	<ol style="list-style-type: none"> 1. Clean burner orifice (see <i>Cleaning and Maintenance</i>, page 14) 2. Replace gas regulator1.
Slight smoke or odor during initial operation	<ol style="list-style-type: none"> 1. Residues from manufacturing processes 2. Not enough air 3. Gas regulator defective 	<ol style="list-style-type: none"> 1. Problem will stop after a few hours of operation 2. Check burner for dirt and debris. If found, clean burner (see <i>Cleaning and Maintenance</i>, page 14) 3. Replace gas regulator
Dark residue on logs or inside of fireplace	<ol style="list-style-type: none"> 1. Improper log placement 2. Air holes at burner inlet blocked 3. Burner flame holes blocked 	<ol style="list-style-type: none"> 1. Properly locate logs (see <i>installing logs</i>, page 27) 2. Clean out air holes at burner inlet. Periodically repeat as needed. 3. Remove blockage or replace burner
Heater produces a clicking/ticking noise just after burner is lit or shut off	<ol style="list-style-type: none"> 1. Metal expanding while heating or contracting while cooling 	<ol style="list-style-type: none"> 1. This is common with most heaters. If noise is excessive, contact qualified service person

**ILLUSTRATED
PARTS BREAKDOWN**

**GSN3021R
GSP3022R**

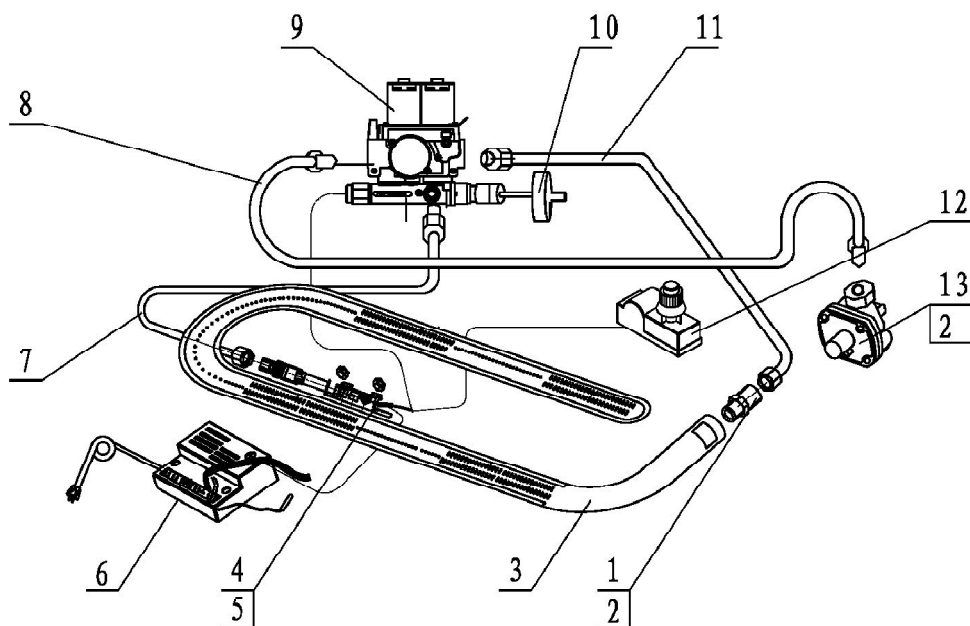

PARTS LIST

**GSN3021R
GSP3022R**

Key No.	PART NUMBER	DESCRIPTION	QTY	
			NG	LP
1.	QL027-01	Burner(NG)	1	
2.	QL028-01	Burner(LP)		1
3.	NBY28-025B3	Burner Assembly	1	
	NBY28-160B3	Burner Assembly		1
4.	ND1819x400-C	ODS	1	
5.	ND1818x400-C	ODS		1
6.	NAYB03-00	Control Box	1	1
7.	QB33300R	Outlet Tube Assembly	1	1
8.	QB31300R	Inlet Tube Assembly	1	1
9.	NV2022	Override Control Value	1	1
10.	MCL082-01	Knob	1	1
11.	QB32300R	Inlet Tube Assembly	1	1
12.	AL092-01	Electronic Ignitor	1	1
13.	NRV81FI-3	Regulator	1	
	NRV81FI-8	Regulator		1

**ILLUSTRATED
PARTS BREAKDOWN**

**GSN3021R
GSP3022R**

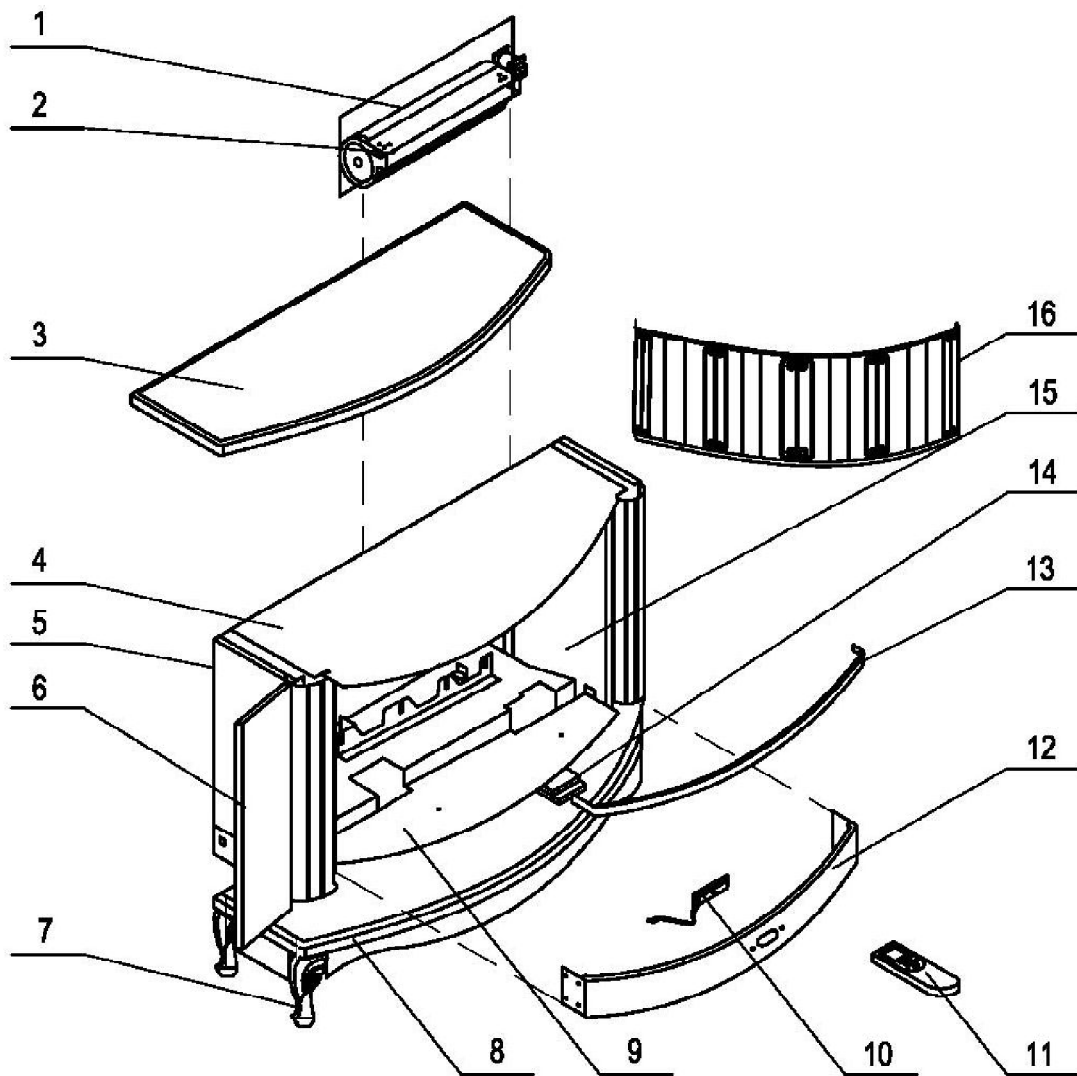

PARTS LIST

GSN3021R

GSP3022R

Key No.	PART NUMBER	DESCRIPTION	QTY	
			NG	LP
1	QL016-03	Blower mount panel	1	1
2	20-6028	Fan	1	1
3	QL012-03	Top panel	1	1
4	QL002-03	Top louver	1	1
5	VL067-01	ON/OFF switch	1	1
6	QL015-05	Door	2	2
7	QL019-04	Leg	1	1
8	QL013-03A	Pedestal	1	1
9	QL007-03	firebox bottom panel	1	1
10	NAYB02-00	Receiver ASM	1	1
11	NAYB01-00	Remote control	1	1
12	QL009-04R	lower front panel	1	1
13	QL007-03A	Fire box floor	1	1
14	NAYB03-00	Control box	1	1
15	QL001-04A	Column	2	2
16	QB29100	Screen	1	1

PLACING INSTRUCTION

Follow the procedures below and the instruction drawings to put log sets in place to the gas stove(indoor vent-free).

THE LOG'S PACKAGE IS LOCATED INSIDE THE UNIT



THEN REMOVE SCREEN AND TAKE OUT THE LOG'S PACKAGE



FIRST REMOVE TWO TOP SCREWS FROM SCREEN



BOTTOM PANEL



BOTTOM PANEL

NOTICE: THE CORRECT POSITION OF THE LOGS SHOULD NOT IMPINGE ON THE FLAME.

INSTALLATION INSTRUCTIONS FOR LOG SETS

1. All logs

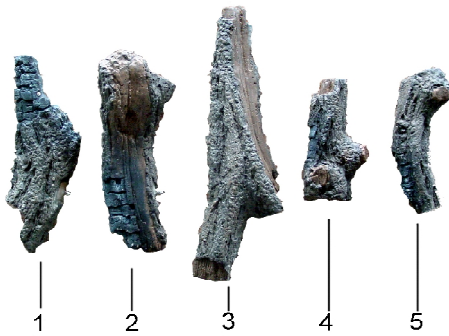

FIG(1)



FIG(2)

STEP 1: Install the log 1 on the left rear angle iron. see FIG(2)

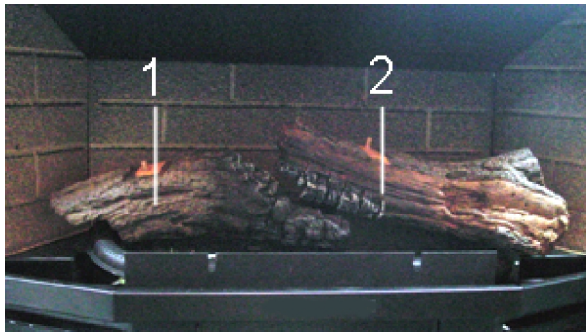

FIG(3)

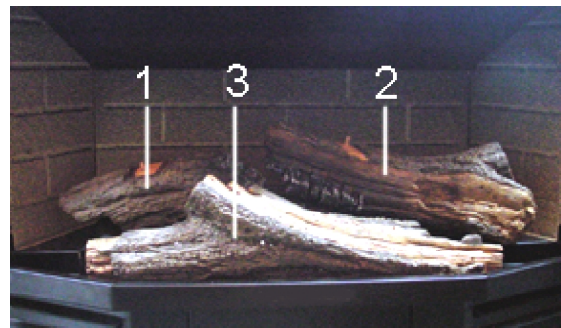

FIG(4)

STEP 2: Install the log 2 on the right rear angle iron. see FIG(3)

STEP 3: Install the log 3 on the front angle iron. See FIG(4).

STEP 4: Insert the pinhole on the upper part of log 4 into the pin on the left side of log 1. Place the lower part of log 4 on the flat roof at the left side of log 3 See FIG(5).

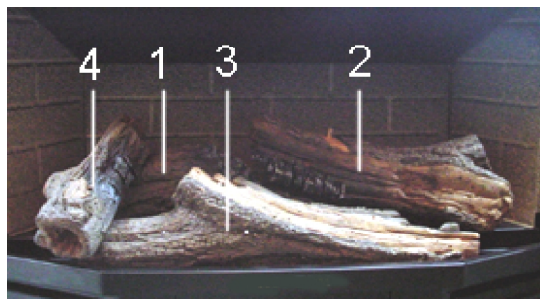

FIG(5)



FIG(6)

STEP 4: Insert the pinhole on the upper part of log 5 into the pin on the log 2. Place the lower part of log 5 on the flat roof at the left side of log 3 . See FIG(6).