

Kozy-World®

FULL SIZE VENT-FREE
FIREPLACE

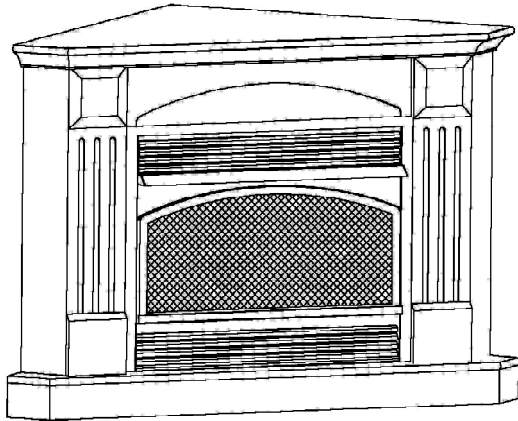

GFNC3025 GFPC3026

OWNER'S OPERATION AND INSTALLATION MANUAL

⚠ WARNING: If the information in this manual is not followed exactly, a fire or explosion may result causing property damage, personal injury, or loss of life.

Do not store or use gasoline or other flammable vapors and liquids in the vicinity of this or any other appliance.

WHAT TO DO IF YOU SMELL GAS

- Do not try to light any appliance.
- Do not touch any electrical switch; do not use any phone in your building.
- Immediately call your gas supplier from a neighbor's phone. Follow the gas supplier's instructions.
- If you cannot reach your gas supplier, call the fire department.

Installation and service must be performed by a qualified installer, service agency, or the gas supplier.

⚠ WARNING: This is an unvented gas-fired heater. It uses air (oxygen) from the room in which it is installed. Provisions for adequate combustion and ventilation air must be provided. Refer to Air For Combustion and Ventilation section on page 5 of this manual.

⚠ WARNING: Improper installation, adjustment, alteration, service or maintenance can cause injury or property damage. Refer to this manual for correct installation and operational procedures. For assistance or additional information consult a qualified installer, service agency, or gas supplier.



This appliance may be installed in an aftermarket*, permanently located, manufactured (mobile) home, where not prohibited by local codes.

This appliance is only for use with the type of gas indicated on the rating plate. This appliance is not convertible for use with other gases.

*Aftermarket: Completion of sale, not for purpose of resale, from the manufacturer.

Consumer: Please retain these instructions for future use.

Installer: Please Leave these instructions with the consumer

World-Marketing of American, Inc.
P.O. Box 192, Rt. 22 West
Mill Creek, PA 17060

KOZY-WORLD PHONE NUMBER: (814) 643-1775

<http://www.worldmktng.com>

KW-FBL035-01HR/T-0608

Table of Contents

| | |
|---|----|
| Important Safety Information | 2 |
| Air for Combustion and Ventilation..... | 5 |
| Assembly Installation..... | 7 |
| Installation..... | 9 |
| Operating Heater, TA Models..... | 13 |
| Cleaning & Maintenance..... | 14 |
| Troubleshooting..... | 15 |
| Specifications..... | 16 |
| Replacement | 16 |
| Parts List..... | 17 |

IMPORTANT SAFETY INFORMATION

IMPORTANT: Read this owner's manual carefully and completely before trying to assemble, operate, or service this heater. Improper use of this heater can cause serious injury or death from burns, fire, explosion, electrical shock, and carbon monoxide poisoning.

⚠ DANGER: Carbon monoxide poisoning may lead to death!

Carbon Monoxide Poisoning: Early signs of carbon monoxide poisoning resemble the flu with headaches, dizziness, or nausea. If you have these signs, the heater may not be working properly. Get fresh air immediately! Have heater serviced. Some people are more affected by carbon monoxide than others. These include pregnant women, people with heart, or lung disease, anemia, those under the influence of alcohol, and those at high altitudes.

Natural and Propane/LP Gas: Natural and Propane/LP gas is odorless. An odor-making agent is added to the gas. The odor helps you detect a gas leak. However, the odor added to the gas can fade. Gas may be present even though no odor exists.

Make certain you read and understand all warnings. Keep this manual for reference. It is your guide to safe and proper operation of this heater.

⚠ WARNING: Any change to this fireplace or its controls can be dangerous.

⚠ WARNING: Do not allow fans to blow directly into the heater. Avoid any drafts that alter burner flame patterns. Ceiling fans can create drafts that alter burner flame patterns. Altered burner patterns can cause sooting.

⚠ WARNING: Do not use a blower insert, heat exchanger insert, or other accessory not approved for use with this heater.

Due to high temperatures, the appliance should be located out of traffic and away from furniture and draperies.

Do not place clothing or other flammable material on or near the appliance. Never place any objects in the fireplace.

Heater becomes very hot when running fireplace. Keep children and adults away from hot surfaces to avoid burns or clothing ignition. Fireplace will remain hot for a time after shutdown. Allow surfaces to cool before touching.

Carefully supervise young children when they are in the room with fireplace.

You must operate this heater with the heater screen in place. Make sure heater screen is in place before running heater.

Keep the appliance area clear and free from combustible materials, gasoline, and other flammable vapors and liquids.

WARNING

Model GFNC3025 is equipped for Natural gas. Field conversion is not permitted.

Model GFPC3026 is equipped for Propane gas. Field conversion is not permitted.

1. This appliance is only for use with the type of gas indicated on the rating plate. This appliance is not convertible for use with other gases.
2. Do not place Propane/LP supply tank(s) inside any structure. Locate Propane/LP supply tank(s) outdoors.
3. If you smell gas
 - Shut off gas supply.
 - Do not try to light any appliance.
 - Do not touch any electrical switch: do not use any phone in your building.
 - Immediately call your gas supplier from a neighbor's phone. Follow the gas supplier's instructions.
 - If you cannot reach your gas supplier, call the fire department. and to replace any part of the control system, and any gas control, which has been under water.
4. This heater shall not be installed in a bedroom or bathroom.
5. Do not use this heater as a wood-burning heater. Use only the logs provided with the heater.
6. Do not add extra logs or ornaments such as pine cones, vermiculite, or rock wool. Using these added items can cause sooting. Do not add lava rock around base. Rock and debris could fall into the control area of heater. After servicing, always replace screen before operating heater.
7. You must operate this heater with the heater screen in place. Make sure heater screen is in place before running heater.

SAFETY INFORMATION

Continued

8. This heater is designed to be smokeless. If logs ever appear to smoke, turn off heater and call a qualified service person.
Note: During initial operation, slight smoking could occur due to log curing and heater burning manufacturing residues.
9. To prevent the creation of soot, follow the instructions in *Cleaning and Maintenance* (page 12).
10. Before using furniture polish, wax, carpet cleaner, or similar products, turn heater off. If heated, the vapors from these products may create a white powder residue within burner box or on adjacent walls or furniture.
11. This heater needs fresh air ventilation to run properly. This heater has an Oxygen Depletion Sensing (ODS) safety shutoff system. The ODS shuts down the heater if not enough fresh air is available. See *Air for Combustion and Ventilation*, pages 5 through 6. If heater keeps shutting off, see *Troubleshooting*, pages 16 through 17.
12. Do not run heater:
 - Where flammable liquids or vapors are used or stored.
 - Under dusty conditions.
13. Do not use this heater to cook food or burn paper or other objects.
14. Do not use this heater if any part has been under water. Immediately call a qualified service technician to inspect the room heater.
15. Turn off and unplug heater and let cool before servicing. Only a qualified service person should service and repair heater.
16. Operating heater above elevations.

17. Do not operate heater if any log is broken. Do not operate heater if any log is chipped (dime-sized or larger). of 4,500 feet could cause pilot outage.
18. To prevent performance problems, do not use propane/ LP fuel tank of less than 100 lbs. capacity.

QUALIFIED INSTALLING AGENCY

Installation and replacement of gas piping, gas utilization equipment or accessories and repair and servicing of equipment shall be performed only by a qualified agency. The term "qualified agency" means any individual, firm, corporation, or company that either in person or through a representative is engaged in and is responsible for (a) the installation, testing, or replacement of gas piping or (b) the connection, installation, testing, repair, or servicing of equipment; that is experienced in such work; that is familiar with all precautions required, and that has complied with all the requirements of the authority having jurisdiction.

PRODUCT FEATURES SAFETY PILOT

This heater has a pilot with an Oxygen Depletion Sensing (ODS) safety shutoff system. The ODS/pilot is a required feature for vent-free room heaters. The ODS/pilot shuts off the heater if there is not enough fresh air.

State of Massachusetts: The installation must be made by a licensed plumber or gas fitter in the Commonwealth of Massachusetts.

Sellers of unvented propane or natural gas-fired supplemental room heaters shall provide to each purchaser a copy of 527 CMR 30 upon sale of the unit.

In the state of Massachusetts, unvented propane or natural gas-fired space heaters shall be prohibited in bedrooms and bathrooms.

In the State of Massachusetts the gas cock must be a "T" handle type. The State of Massachusetts requires that a flexible appliance connector cannot exceed three feet in length.

LOCAL CODES

Install and use heater with care. Follow all local codes. In the absence of local codes, use the latest edition of The National Fuel Gas Code, ANSZ 223.1, also known as NFPA 54*.

*Available from:

American National Standards Institute, Inc.

1430 Broadway
New York, NY 10018

National Fire Protection Association, Inc.

Batterymarch Park
Quincy, MA 02269

This heater is designed for vent-free operation. State and local codes in some areas prohibit the use of vent-free heaters.

UNPACKING

1. Remove top inner pack.
2. Tilt carton so that fireplace is upright.
3. Remove protective side packaging.
4. Slide fireplace out of carton.
5. Remove protective plastic wrap.
6. Install fireplace according to installation instructions for corner.
7. Hold the screen lift and pulling forward.
8. Remove log set by cutting plastic ties.
9. Carefully unwrap log.
10. Check for any shipping damage. If stove or log is damaged, promptly inform dealer where you bought stove.

PRODUCT IDENTIFICATION

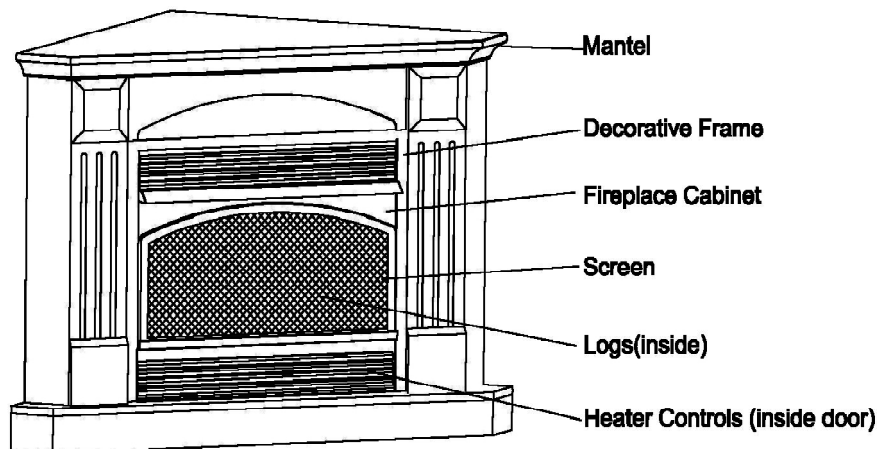

Figure1- Vent Free LP/NG Gas Fireplace

WATER VAPOR: A BY-PRODUCT OF UNVENTED ROOM HEATERS

Water vapor is a by-product of gas combustion. An unvented room heater produces approximately one(1) ounce (30ml) of water for every 1,000 BTU's(.3KW's)of gas input per hour.

Unvented room heaters are recommended as supplemental heater(a room). Rather than a primary heat source (an entire house). In most supplemental heat applications, the water vapor does not create a problem. In most applications,the water vapor enhances the low humidity atmosphere experienced during cold weather.The following steps will help insure that water vapor does not become a problem.

- 1.Be sure the heater is a sized properly for the application, including ample combustion air and circulation air.
- 2.If high humidity is experienced,dehumidifier may be used to help lower the water vapor content of the air.
- 3.Do not use an unvented room heater as the primary heat source.

AIR FOR COMBUSTION AND VENTILATION

⚠ WARNING: This heater shall not be installed in a confined space or unusually tight construction unless provisions are provided for adequate combustion and ventilation air. Read the following instructions to insure proper fresh air for this and other fuel-burning appliances in your home.

PROVIDING ADEQUATE VENTILATION

The following are excerpts from *National Fuel Gas Code, NFPA 54/ANSI Z 223.1, Section 5.3, Air for Combustion and Ventilation*.

All spaces in homes fall into one of the three following ventilation classifications:

1. Unusually Tight Construction
2. Unconfined Space
3. Confined Space

The information on pages 5 through 6 will help you classify your space and provide adequate ventilation.

Confined and Unconfined Space

The National Fuel Gas Code, ANS Z223.1 defines a confined space as a space whose volume is less than 50 cubic feet per 1,000 Btu per hour (4.8 m³ per kw) of the aggregate input rating of all appliances installed in that space and an unconfined space as a space whose volume is not less than 50 cubic feet per 1,000 Btu per hour (4.8 m³ per kw) of the aggregate input rating of all appliances installed in that space. Rooms communicating directly with the space in which the appliances are installed*, through openings not furnished with doors, are considered a part of the unconfined space.

This heater shall not be installed in a confined space or unusually tight construction unless provisions are provided for adequate combustion and ventilation air.

* Adjoining rooms are communicating only if there are doorless passageways or ventilation grills between them.

Unusually Tight Construction

The air that leaks around doors and windows may provide enough fresh air for combustion and ventilation. However, in buildings of unusually tight construction, you must provide additional fresh air.

Unusually tight construction is defined as construction where:

- a) walls and ceilings exposed to the outside atmosphere have a continuous water vapor retarder with a rating of one perm (6×10^{-11} kg per pa-sec-m²) or less with openings gasketed or sealed and
- b) weather stripping has been added on windows that can be opened and doors and
- c) caulking or sealants are applied to areas such as joints around window and door frames, between sole plates and floors, between wall-ceiling joints, between wall panels, at penetrations for plumbing, electrical, and gas lines, and at other openings.

If your home meets all of the three criteria above, you must provide additional fresh air. See *Ventilation Air From Outdoors* (page 6).

If your home does not meet all of the three criteria above, proceed to *Determining Fresh-Air Flow For Heater Location* (below).

DETERMINING FRESH-AIR FLOW FOR HEATER LOCATION

Determining if You Have a Confined or Unconfined Space

Use this worksheet to determine if you have a confined or unconfined space.

Space: Includes the room in which you will install heater plus any adjoining rooms with doorless passageways or ventilation grills between the rooms.

1. Determine the volume of the space (length×width×height).

Length×Width×Height=_____cu.ft. (volume of space)

Example: Space size 20ft. (length)×16ft.(width)×8ft. (ceiling height)=2560cu. ft. (volume of space)

If additional ventilation to adjoining room is supplied with grills or openings, add the volume of these rooms to the total volume of the space.

2. Divide the space volume by 50 cubic feet to determine the maximum Btu/Hr the space can support.

_____(volume of space)÷50 cu. ft.=(Maximum Btu/Hr the space can support)

Example: 2560 cu. ft. (volume of space)÷50 cu.ft.=51.2 or 51,200(maximum Btu/Hr the space can support)

3. Add the Btu/Hr of all fuel burning appliances in the space.

| | | |
|-------------------------|---------|--------|
| Vent-free heater | _____ | Btu/Hr |
| Gas water heater* | _____ | Btu/Hr |
| Gas furnace | _____ | Btu/Hr |
| Vented gas heater | _____ | Btu/Hr |
| Gas heater logs | _____ | Btu/Hr |
| Other gas appliances* + | _____ | Btu/Hr |
| Total | = _____ | Btu/Hr |

Example:

| | | |
|------------------|----------|--------|
| Gas water heater | 30,000 | Btu/Hr |
| Vent-free heater | + 26,000 | Btu/Hr |
| Total | = 56,000 | Btu/Hr |

*Do not include direct-vent gas appliances. Direct-vent draws combustion air from the outdoors and vents to the outdoors.

4. Compare the maximum Btu/Hr the space can support with the actual amount of Btu/Hr used.

_____ Btu/Hr (maximum the space can support)

_____ Btu/Hr (actual amount of Btu/Hr used)

Example : 51,200 Btu/Hr(maximum the space can support)

56,000 Btu/Hr(actual amount of Btu/Hr used)

The space in the above example is a confined space because the actual Btu/Hr used is more than the maximum Btu/Hr the space can support.

You must provide additional fresh air. Your options are as follows:

A. Rework worksheet, adding the space of an adjoining room. If the extra space provides an unconfined space, remove door to adjoining room or add ventilation grills between rooms. See *Ventilation Air From Inside Building (below)*.

B. Vent room directly to the outdoors. See *Ventilation Air From Outdoors (below)*.

C. Install a lower Btu/Hr heater, if lower Btu/Hr size makes room unconfined.

If the actual Btu/Hr used is less than the maximum Btu/Hr the space can support, the space is an unconfined space. You will need no additional fresh air ventilation.

⚠ WARNING: If the area in which the heater may be operated is smaller than that defined as an unconfined space or if the building is of unusually tight construction, provide adequate combustion and ventilation air by one of the methods described in the *National Fuel Gas Code, ANSI Z223.1, Section 5.3* or applicable local codes.

Ventilation Air From Inside Building

This fresh air would come from an adjoining unconfined space. When ventilating to an adjoining unconfined space, you must provide two permanent openings: one within 12" of the ceiling and one within 12" of the floor on the wall connecting the two spaces (see options 1 and 2, Figure 2). You can also remove door into adjoining room (see option 3, Figure 2). Follow the *National Fuel Gas Code, NFPA 54/ANSI Z223.1, Section 5.3, Air for Combustion and Ventilation* for required size of ventilation grills or ducts.

Ventilation Air From Outdoors

Provide extra fresh air by using ventilation grills or ducts. You must provide two permanent openings: one within 12" of the ceiling and one within 12" of the floor. Connect these items directly to the outdoors or spaces open to the outdoors. These spaces include attics and crawl spaces. Follow the *National Fuel Gas Code, NFPA 54/ANSI Z223.1, Section 5.3, Air for Combustion and Ventilation* for required size of ventilation grills or ducts.

IMPORTANT: Do not provide openings for inlet or outlet air into attic if attic has a thermostat-controlled power vent. Heated air entering the attic will activate the power vent.

⚠ WARNING: Rework worksheet, adding the space of the adjoining unconfined space. The combined spaces must have enough fresh air to supply all appliances in both spaces.

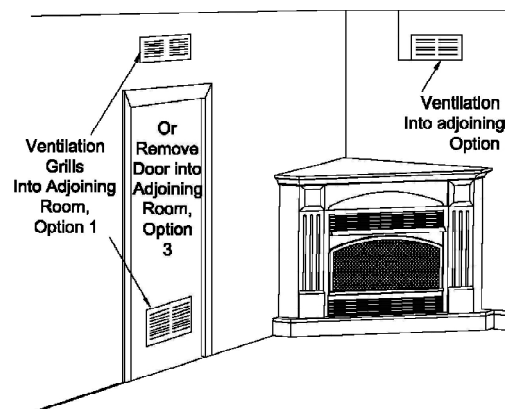

Figure 2-Ventilation Air from Inside Building

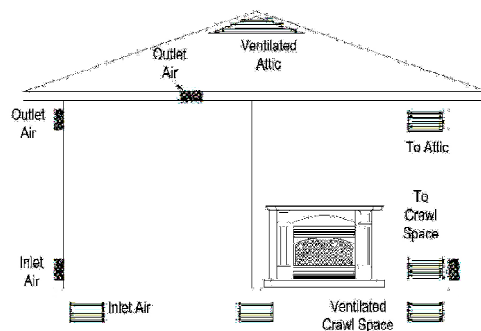

Figure 3-Ventilation Air from Outdoors

Assembly Instructions

For CORNER SURROUND AND HEARTH

READ INSTRUCTIONS BEFORE BEGINNING INSTALLATION. Check to see that you have the following. If any part or parts are missing, contact the dealer where you bought the surround and hearth.

TOOLS REQUIRED:

Measuring Tape, Pencil, Level, #2 Phillips Screw Driver, Hammer, Electric Drill, 5/16" Drill Bit, Hand or Electric Saw

INSTALLATION:

1. Surround must be installed flush with wall. Baseboards will prevent proper installation of surround. Baseboards can be altered to fit surround by cutting that part within 34 1/2" distance from the wall corner.
2. Surround must be attached to either a wall stud or wall anchor. Use a tape measure to determine correct height from floor to location of mounting strips. (See Figure 1). Make sure point of the mitered edge of mounting strip touches the corner. Use a level to ensure mounting strips are evenly balanced.

IMPORTANT: Failure to balance mounting strips with a level could result in uneven surfaces on fully assembled surround.

3. Fasten mounting strip to wall by inserting 2" screws provided along the predrilled holes of mounting strip. If predrilled holes of mounting strip do not line up with wall studs, drill new holes where wall studs are or attach to wall with wall anchors. (See Step 4 below.)
4. To use wall anchors, drill holes at marked location using 5/16" drill bit. Fold wall anchor (see Figure 2) and insert (wings first) into hole. Tap anchor flush into wall. For thin walls, insert red key into wall anchor and push to "pop" open anchor wings (see Figure 3).
5. Repeat steps above to attach other mounting strips to wall. Make sure mitered edges fit together to form a clean joint in the corner of the wall.

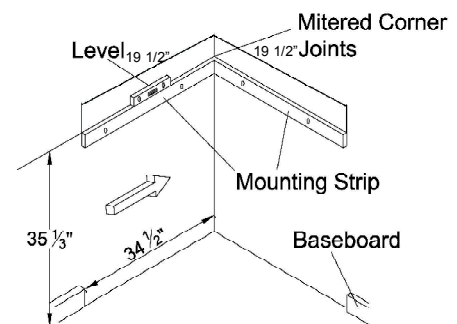

Figure 1

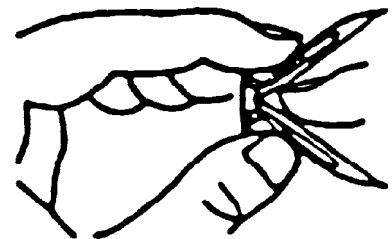

Figure 2

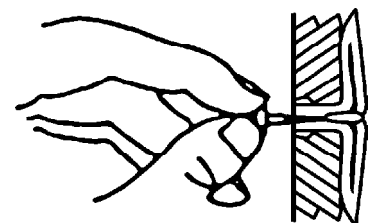

Figure 3

6. Place the assembled fireplace on the middle where it is 30" from the corner and form a 45 degree angle to each side wall. Move the assembled surround to the corner, with side panels close to side walls. Move the fireplace to where it can properly attach the surround.
7. Move the surround away, mark floor or wall behind fireplace for gas line entrance. Connect inlet gas pipe.
IMPORTANT: Make sure there are no electrical lines where gas piping will go through floor or wall.
8. Turn up the back of mantel top, the special spring will lock the rear mantel top in position, then use screws to secure bracket as show in Figure 5 make sure the front and rear mantel top are in the same level.
9. Move the surround back. Set surround top on top of mounting strips and mantel front. After properly installing the top, attach surround top to mounting strip using finishing nails.
10. Push the base to the bottom of surround, close to the right and left sides.
11. Install fireplace per Homeowner's Installation Manual.

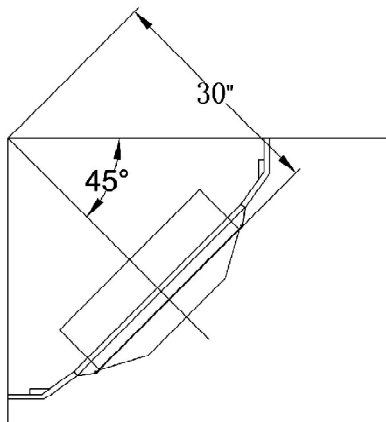

Figure 4

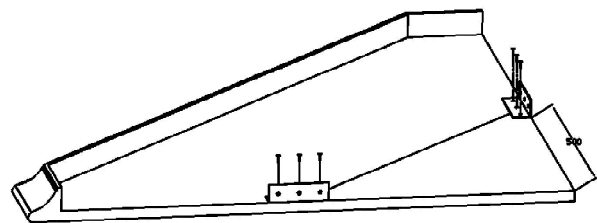

Figure 5

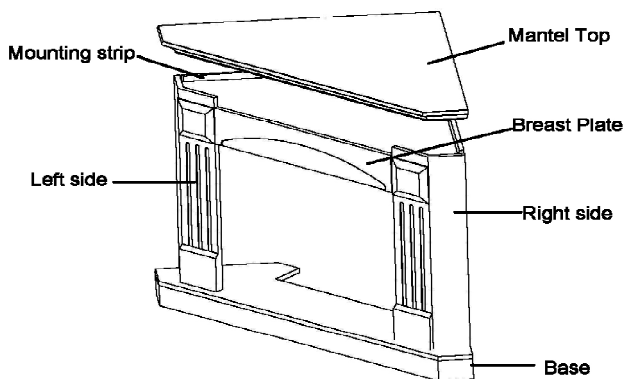

Figure 6

INSTALLATION

▲ NOTICE: This heater is intended for use as supplemental heat. Use this heater along with your primary heating system. Do not install this heater as your primary heat source. If you have a central heating system, you may run system's circulating blower while using heater. This will help circulate the heat throughout the house.

▲ WARNING: A qualified technician person must install heater. Follow all local codes.

▲ WARNING: Never install the heater

- in a bedroom or bathroom
- in a recreational vehicle
- where curtains, furniture, clothing, or other flammable objects are less than 42 inches from the front, top, or sides of the heater
- in high traffic areas
- in windy or drafty areas

▲ CAUTION: This heater creates warm air currents. These currents move heat to wall surfaces next to heater. Installing heater next to vinyl or cloth wall coverings or operating heater where impurities (such as tobacco smoke, aromatic candles, cleaning fluids, oil or kerosene lamps, etc.) in the air exist, may discolor walls.

▲ WARNING: Maintain the minimum clearances. If you can, provide greater clearances from floor, ceiling, and adjoining side and back walls.

Front View

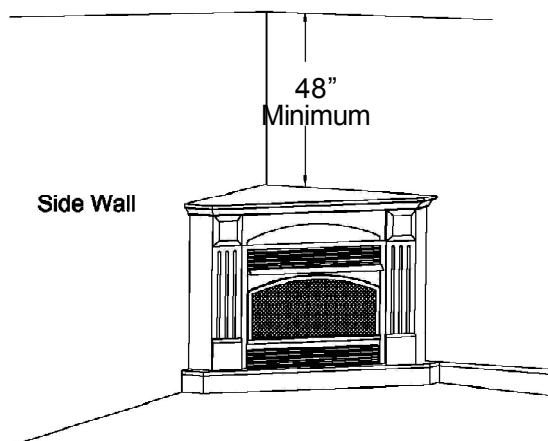

Corner

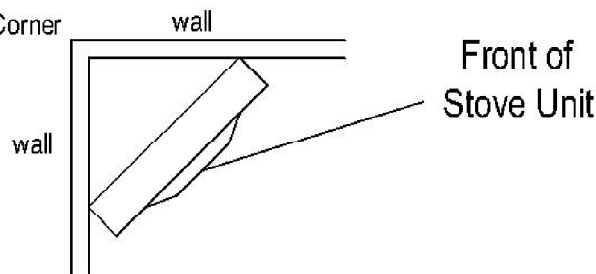

Figure 4 - Minimum Clearance to Wall and Ceiling

IMPORTANT: Vent-free heaters add moisture to the air. Although this is beneficial, installing heater in rooms without enough ventilation air may cause mildew to form from too much moisture. See Air for Combustion and Ventilation, pages 5 through 6.

CHECK GAS TYPE

Use only the type of gas indicated on the plate. If your gas supply can not meet that requirement, do not install heater. Call the dealer where you purchased heater, for the proper type of heater.

CLEARANCES TO COMBUSTIBLES

Carefully follow the instructions below. This fireplace is a freestanding unit designed to set directly on the floor.

IMPORTANT: You must maintain minimum wall and ceiling clearances during installation. The minimum clearances are shown in Figure 4. Measure from outermost point of stove top.

Minimum Wall and Ceiling Clearances (see Figure 4)

- A. Clearances from outermost point of fireplace top to any combustible side wall should not be less than 0 inches.
- B. Clearances from the fireplace top to the ceiling should not be less than 48 inches.

INSTALLATION

Continued

CONNECTING TO GAS SUPPLY

⚠ WARNING: A qualified technician must connect heater to gas supply. Follow all local codes.

⚠ CAUTION: Never connect heater directly to the gas supply. This heater requires an external regulator (not supplied). Install the external regulator between the heater and gas supply.

INSTALLATION ITEMS NEEDED

Before installing heater, make sure you have the items listed below.

- piping (check local codes)
- sealant (resistant to propane/LP gas)
- equipment shutoff valve*
- test gauge connection**
- sediment trap
- tee joint
- pipe wrench
- Flexible Gas hose (check local code)

* A CSA design-certified equipment shutoff valve with 1/8" NPT tap is an acceptable alternative to test gauge connection. Purchase the optional CSA design-certified equipment shutoff valve from your dealer.

⚠ WARNING: Never connect heater to private (non-utility) gas wells. This gas is commonly known as wellhead gas.

Front View

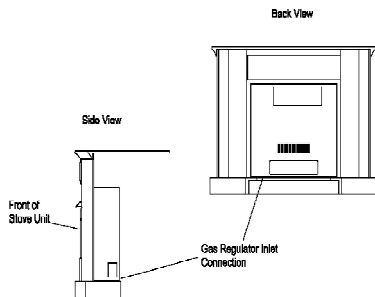

Figure 5-Gas Regulator Location and Gas Line Access Into Fireplace Cabinet

The installer must supply an external regulator. The external regulator will reduce incoming gas pressure. You must reduce incoming gas pressure to between 11 and 14 inches of water. If you do not reduce incoming gas pressure, heater regulator damage could occur. Install external regulator with the vent pointing down as shown in Figure 6. Pointing the vent down protects it from freezing rain or sleet.

⚠ CAUTION: Only use a new black iron or steel pipe. Internally-tinned copper tubing may be used in certain areas. Check your local codes. Use pipe of 1/2" diameter or greater to allow proper volume gas to heater. If pipe is too small, undue loss of pressure will occur.

Installation must include an equipment shutoff valve, union, and plugged 1/8" NPT tap. Locate NPT tap within reach for test gauge hook up. NPT tap must be upstream from heater (see Figure 7).

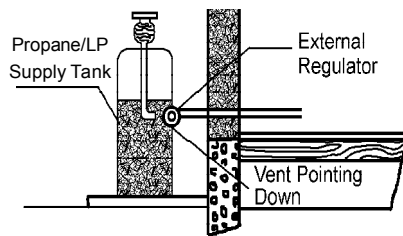

Figure 6-External Regulator With Vent Pointing Down

IMPORTANT: Install equipment shutoff valve in an accessible location. The equipment shutoff valve is for turning on or shutting off the gas to the appliance. Apply pipe joint sealant lightly to male threads. This will prevent excess sealant from going into pipe. Excess sealant in pipe could result in clogged heater valves.

⚠ CAUTION: Use pipe joint sealant that is resistant to gas (PROPANE or NG).

We recommend that you install a sediment trap in a supply line as shown in Figure 7. Locate sediment trap where it is within reach for cleaning. Install in the piping system between fuel supply and heater. Locate sediment trap where trapped matter is not likely to freeze. A sediment trap traps moisture and contaminants. This keeps them from going into heater controls. If sediment trap is not installed or is installed incorrectly, heater may not run properly.

⚠ CAUTION: Avoid damage to regulator. Hold gas regulator with wrench when connecting into gas piping and/or fittings.

NG Models:
5" to 10.5" W.C.
Gas supplier provide external regulator for natural gas

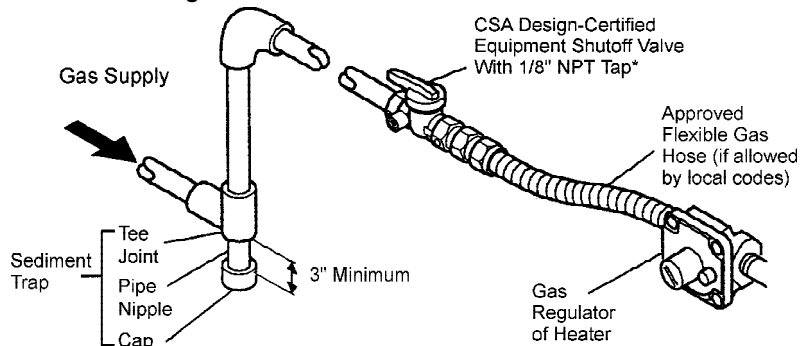

Figure 7-Gas Connection

* Purchase the optional CSA design-certified equipment shutoff valve from your dealer.

** Minimum inlet pressure for purpose of input adjustment.

INSTALLATION

Continued

CHECKING GAS CONNECTIONS

⚠ WARNING: Test all gas piping and connections for leaks after installing or servicing. Correct all leaks immediately.

⚠ WARNING: Never use an open flame to check for a leak. Apply a mixture of liquid soap and water to all joints. Bubbles forming show a leak. Correct all leaks immediately.

⚠ CAUTION: Make sure external regulator has been installed between gas supply and heater. See guidelines under *Connecting to Gas Supply* (page8).

Pressure Testing Gas Supply Piping System

Test Pressures In Excess Of 1/2 PSIG(3.5kPa)

1. Disconnect heater with its appliance main gas valve (control valve) and equipment shutoff valve from gas supply piping system. Pressures in excess of 1/2 psig will damage heater regulator.
2. Cap off open end of gas pipe where equipment shutoff valve was connected.
3. Pressurize supply piping system by either using compressed air or opening gas supply tank valve.
4. Check all joints of gas supply piping system. Apply mixture of liquid soap and water to gas joints. Bubbles forming show a leak.
5. Correct all leaks immediately.
6. Reconnect heater and equipment shutoff valve to gas supply. Check reconnected fittings for leaks.

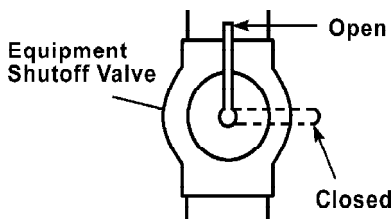

Figure 8 -Equipment Shutoff Valve

Pressure Testing Heater Gas Connections

1. Open equipment shutoff valve (see Figure 8).
2. Open gas supply tank valve.
3. Make sure control knob of heater is in the OFF position.
4. Check all joints from equipment shutoff valve to control valve (Figure 9). Apply mixture of liquid soap and water to gas joints. Bubbles forming show a leak.
5. Correct all leaks immediately.
6. Light heater (see *Operating Heater*, page 11). Check all other internal joints for leaks.
7. Turn off heater (see *Operation of Turn-Off*, page 11).

Test Pressures Equal To or Less Than 1/2 PSIG(3.5 kPa)

1. Close equipment shutoff valve (see Figure 8).
2. Pressurize supply piping system by either using compressed air or opening gas supply tank valve.
3. Check all joints from gas meter to equipment shutoff valve(see Figure 9). Apply mixture of liquid soap and water to gas joints. Bubbles forming show a leak.
4. Correct all leaks immediately.

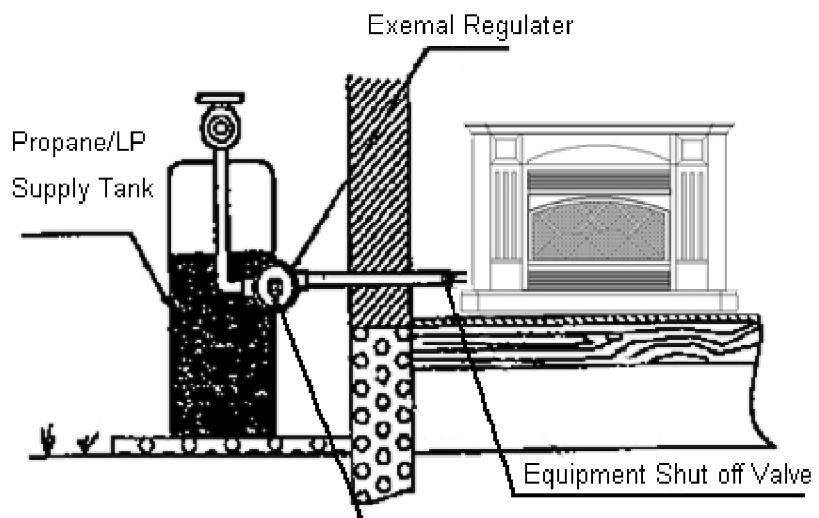

Figure 9 -Checking Gas Joints

INSTALLATION

Continued

INSTALLING LOGS

⚠ WARNING: Failure to position the parts in accordance with these diagrams or failure to use only parts may result in property damage or personal injury.

⚠ CAUTION: After installation and periodically thereafter, check to ensure that no flame comes in contact with any log. With the heater set to High, check to see if flames contact any log. If so, reposition logs according to the log installation instructions in this manual. Flames contacting logs will create soot.

Log Set

Burner Ports

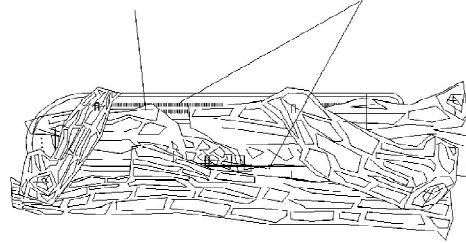

Figure 10-Installing Log Set

IMPORTANT: Make sure log does not cover any burner ports (see Figure 10).

It is very important. To install the logs exactly as instructed. Do not modify logs. Only use logs supplied wall heater.

FIG(1)



1. All logs.

FIG(2)



STEP 1: Install log 1 onto the two slots in the rear plate as shown.

FIG(3)

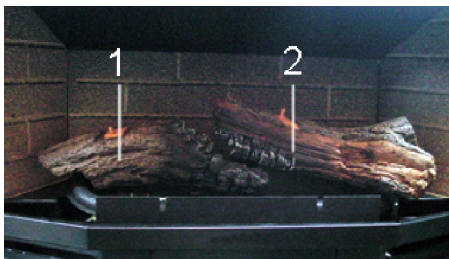

STEP 2: Install log 2 onto the two slots in the rear plate as shown.

FIG(4)

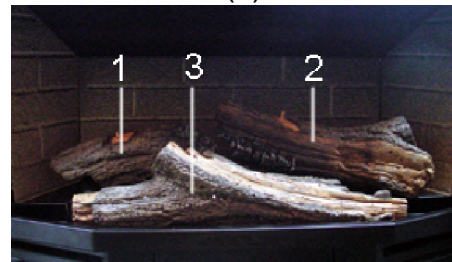

STEP 3: Install log 3 onto the two slots in the front plate as shown.

FIG(5)

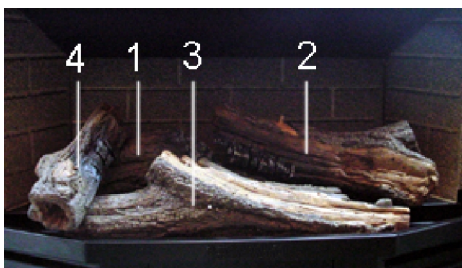

STEP 4: Insert the recess hole on the bottom of log 4 onto the pin on log 1, with the outer end of log 4 placed on log 3 as shown.

FIG(6)



STEP 5: Insert the recessed hole on the bottom of log 5 onto the pin on log 2, with the outer end of log 5 placed on log 3 as shown.

OPERATING HEATER

FOR YOUR SAFETY

WARNING: If you do not follow these instructions exactly, a fire or explosion may result causing property damage, personal injury or loss of life.

NOTICE: During initial operation of new fireplace, burning logs will give off a paper-burning smell. Orange flame will also be present. Open a window to vent smell. This will only last a few hours.

CAUTION: Do not try to adjust heating levels by using the equipment shutoff valve.

- A. This appliance has a pilot which must be lighted by control system. When lighting the pilot, follow these instructions exactly.
- B. BEFORE LIGHTING smell all around the appliance area for gas. Be sure to smell next to the floor because some gas is heavier than air and will settle on the floor.

WHAT TO DO IF YOU SMELL GAS

- Do not try to light any appliance.
 - Do not touch any electrical switch; do not use any phone in your building.
 - Immediately call your gas supplier from a neighbor's phone. Follow the gas supplier's instructions.
 - If you cannot reach your gas supplier, call the fire department.
- C. Use only your hand to push in control knob. Never use tools. If the appliance could not operate, don't try to repair it. Call a qualified service technician or gas supplier. Forced or attempted repair may result in a fire or explosion.
- D. Do not use this appliance if any part has been under water. Immediately call a qualified service technician to inspect the appliance and to replace any part of the control system and any gas control which has been under water.

LIGHTING INSTRUCTIONS

1. STOP! Read the safety information, page 2.
2. Make sure equipment shutoff valve is fully open.
3. Turn control knob clockwise ↻ to the OFF position.
4. Wait five (5) minutes to clear out any gas. Then smell for gas, including near the floor. If you smell gas, STOP! Follow "B" in the safety information, page 2. If you don't smell gas, go to the next step.
5. Turn control knob counterclockwise ↻ to the PILOT position. Press in control knob for five seconds (see Figure 11).

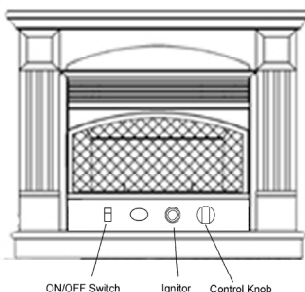

Note: You may be running this fireplace for the first time after hooking up to gas supply. If so, the control knob may need to be pressed in for 30 seconds or less. This will allow air to bleed from the gas system. 6. With control knob pressed in, press and release ignitor button. This will light pilot. The pilot is attached to the front burner. If needed, keep pressing ignitor button until pilot lights.

Note: If pilot does not stay lit, contact a qualified service technician or gas supplier for repairs. Until repairs are made, light pilot with match. To light pilot with match, see Manual Lighting Procedure.

7. Keep control knob pressed in for 30 seconds after lighting pilot. After 30 seconds release control knob. If control knob does not pop out when

released, contact a qualified technician or gas supplier for repairs.

Note: If pilot goes out, repeat steps 3 through 7. This fireplace has a safety interlock system. Wait one (1) minute for system to reset before lighting pilot again.

8. Turn control knob counter-clockwise ↻ to desired heating level. The burners should light. Set control knob to any heat level between HI and LO.

TO TURN OFF GAS TO APPLIANCE

Shutting Off fireplace

Turn control knob clockwise ↻ to the OFF position.

THERMOSTAT CONTROL OPERATION

The thermostat control knob can be set to any comfort level between HI and LO. The thermostat will gradually modulate the heat output and flame height from higher to lower settings, or pilot, in order to maintain the comfort level you select. The ideal comfort setting will vary by household depending upon the amount of space to be heated, the output of the central heating system, etc.

Note: Selecting the HI setting with the control knob will cause the burners to remain fully on, without modulating down in most cases.

MANUAL LIGHTING PROCEDURE

1. Follow steps 1 through 5 under Lighting Instructions.
2. Press control knob and light pilot with match.
3. Keep control knob pressed in for 30 seconds after lighting pilot. After 30 seconds, release control knob.

PILOT FLAME PATTERN

Figure 12 shows a correct pilot flame pattern. Figure 16 shows an incorrect pilot flame pattern. The incorrect pilot flame is not touching the thermocouple. This will cause the thermocouple to cool. When the thermocouple cools, the heater will shut down. If pilot flame pattern is incorrect, as shown in Figure 13

- Turn heater off (see TO TURN OFF GAS TO APPLIANCE, page 10)
- see *troubleshooting*, page 15.

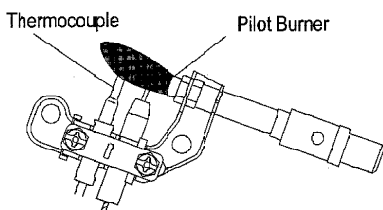

Figure 12 -Correct Pilot Flame Pattern

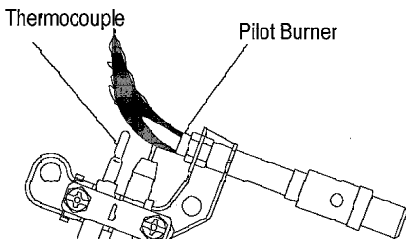

Figure 13 -Incorrect Pilot Flame Pattern

BURNER FLAME PATTERN

Figure 14 shows a correct burner flame pattern. Figure 15 shows an incorrect burner flame pattern. If burner flame is incorrect:

- Turn heater off (see TO TURN OFF GAS TO APPLIANCE, page 10)
- see *troubleshooting*, page 15.

Approx. 3-6" Above
Top of logs



Figure 14 -Correct Flame Pattern with Control Knob Set to High Flame More Than 8" Above Top of logs

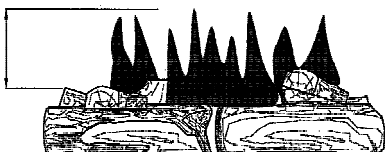

Figure 15 -Incorrect Flame Pattern with Control Knob Set to High Flame

CLEANING AND MAINTENANCE

⚠ WARNING: Disconnect power before attempting any maintenance or cleaning to reduce the risk of fire, electric shock or personal injury. Turn off heater and let cool before cleaning.

⚠ WARNING: Failure to keep primary air openings of burners clean may result in sooting and property damage.

⚠ CAUTION: You must keep control areas, burner, and circulating air passageways of heater clean. Inspect these areas of heater before each use. Have heater inspected yearly by a qualified service person. Heater may need more frequent cleaning due to excessive lint from carpeting, bedding material, pet hair, etc.

CLEANING ODS/IGNITOR AND BURNER

Clean with a vacuum cleaner.

CLEANING BURNER INJECTOR HOLDER AND PILOT AIR INLET HOLE

We recommend that you clean the unit every three months or after 2500 hours of operation. We also recommend that you keep the burner tube and pilot assembly clean and free of dust and dirt. To clean these parts we recommend using compressed air no greater than 30 PSI. You can use a vacuum cleaner in the blow position. If using compressed air in a can, please follow the directions on the can. If you don't follow directions on the can, you could damage the pilot assembly.

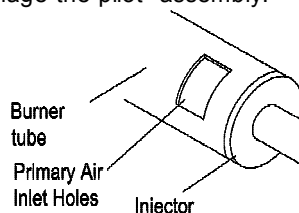

Figure 16 -Injector Holder On Outlet Burner Tube

1. Shut off the unit, including the pilot. Allow the unit to cool for at least thirty minutes.
2. Inspect burner, pilot and primary air inlet holes on injector holder for dust and dirt (see figure 21).
3. Blow air through the ports/slots and holes in the burner.
4. Check the injector holder located at the end of the burner tube

again. Remove any large particles of dust, dirt, lint, or pet hair with a soft cloth or vacuum cleaner nozzle.

5. Blow air into the primary air holes on the injector holder.
6. In case any large clumps of dust have now been pushed into the burner, repeat steps 3 and 4.

Clean the pilot assembly also. A yellow tip on the pilot flame indicates dust and dirt in the pilot assembly. There is a small pilot air inlet hole about two inches from where the pilot flame comes out of the pilot assembly (see Figure 17). With the unit off, lightly blow air through the air inlet hole. You may blow through a drinking straw if compressed air is not available.

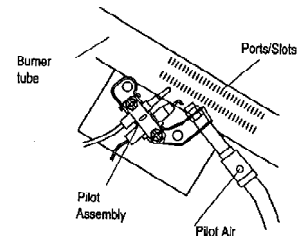

Figure 17 -Pilot Air Inlet Hole

CABINET

Air Passageways

- Use a vacuum cleaner or pressurized air to clean.

Exterior

- Use a soft cloth dampened with a mild soap and water mixture. Wipe the cabinet to remove dust.

LOGS

- If you remove logs for cleaning, refer to *Installing Logs* (page 10) to properly replace logs.
- Replace logs if broken or chipped (dime-sized or larger).

MAIN BURNER

Periodically inspect all burner flame holes with the heater running. All slotted burner flame holes should be open with yellow flame present. All round burner flame holes should be open with a small blue flame present. Some burner flame holes may become blocked by debris or rust, with no flame present. If so, turn off heater and let cool. Either remove blockage or replace burner. Blocked burner flame holes will create soot.

TROUBLESHOOTING

WARNING: If you smell gas

- Shut off gas supply.
 - Do not try to light any appliance.
 - Do not touch any electrical switch; do not use any phone in your building.
 - Immediately call your gas supplier from a neighbor's phone.
- Follow the gas supplier's instructions.
- If you cannot reach your gas supplier, call the fire department.

⚠ WARNING: Make sure that power is turn off before proceeding....

⚠ WARNING: Turn off and let cool before servicing. Only a qualified service person should service and repair fireplace.

⚠ CAUTION: Never use a wire, needle, or similar object to clean ODS/pilot. This can damage ODS/pilot unit.

OBSERVED PROBLEM

POSSIBLE CAUSE

REMEDY

Burner does not light after ODS/pilot is lit

1. Burner orifice clogged
2. Inlet gas pressure is too low
3. Burner orifice diameter is too small
4. Thermocouple leads disconnected or improperly connected
5. Burners will not come in remote position

1. Clean burner (see *Cleaning and Maintenance*, page 13) or replace burner orifice.
2. Contact local propane/LP gas company
3. Replace burner orifice
4. Reconnect leads (see *wiring diagram*)
5. Replace battery in transmitter and receiver

Delayed ignition burner

1. Manifold pressure is too low
2. Burner orifice clogged

1. Contact local gas company
2. Clean burner (see *Cleaning and Maintenance*, page 13)

Burner backfiring during combustion

1. Damaged burner
2. Gas regulator defective

1. Clean burner orifice (see *Cleaning and Maintenance*, page 13)
2. Replace gas regulator

Slight smoke or odor during initial operation

1. Residues from manufacturing processes
2. Not enough air
3. Gas regulator defective

1. Problem will stop after a few hours of operation
2. Check burner for dirt and debris. If found, clean burner (see *Cleaning and Maintenance*, page 13)
3. Replace gas regulator

Dark residue on logs or inside of fireplace

1. Improper log placement
2. Air holes at burner inlet blocked
3. Burner flame holes blocked

1. Properly locate logs (see *installing logs*, page 10)
2. Clean out air holes at burner inlet. Periodically repeat as needed.
3. Remove blockage or replace burner

Heater produces a clicking/ticking noise just after burner is lit or shut off

1. Metal expanding while heating or contracting while cooling

1. This is common with most heaters. If noise is excessive, contact qualified technician.

SPECIFICATIONS

| | GFPC3026 | GFNC3025 |
|---------------------------------------|---------------------------|---------------------------|
| Btu(Variable) | 28000 | 28000 |
| Gas Type | LP Gas | Natural Gas |
| Ignition | Piezo/Automatic | Piezo/Automatic |
| Manifold Pressure | 8"W.C. | 3"W.C. |
| Inlet Gas Pressure (In. of water)* | | |
| Maximum | 14" | 10.5" |
| Minimum | 11" | 5" |
| Dimensions, Inches (H×W×D) | | |
| Heater | 36 1/4"×53 13/16"×29 1/2" | 36 1/4"×53 13/16"×29 1/2" |
| Carton | 40 5/8"×54 3/4"×18 1/8" | 40 5/8"×54 3/4"×18 1/8" |
| Weight, lbs | | |
| Fireplace | 130 | 130 |
| Shipping | 157 | 157 |
| Voltage | 120 | 120 |
| Watt | 27 | 27 |

*For purposes of input adjustment

REPLACEMENT PARTS

REPLACEMENT PARTS

NOTE: Use only original replacement parts. This will protect your warranty coverage for parts replaced under warranty.

PARTS UNDER WARRANTY

Contact authorized dealers of this product. If they can't supply original replacement part(s), call KOZY-WORLD's Technical Service Department at (814)643-1775 for referral information.

- Your name
 - Your address
 - Model and serial numbers of your heater
 - How heater was malfunctioning
 - Type of gas used (propane/LP or NG)
 - Purchase date
 - Warranty card
- Usually, we will ask you to return the defective part to the factory.

PARTS NOT UNDER WARRANTY

Contact authorized dealers of this product. If they can't supply original replacement part(s) call KOZY-WORLD's Parts Department at (814)643-1775 for referral information.

When calling KOZY-WORLD, have ready

- Model number of your heater
- The replacement part number

PARTS LIST
GFNC3025 GFPC3026

This list contains replaceable parts used in your heater. When ordering parts, follow the instructions listed under *Replacement Parts* on page 17 of this manual.

| KEY NO | PART NUMBER | DESCRIPTION | QUALITY | |
|--------|--------------|-----------------|---------|----|
| | | | LP | NG |
| 1 | SIT545-218 | T-STAT VALVE | | 1 |
| | SIT545-200 | T-STAT VALVE | 1 | |
| 2 | NRV81F1-3 | REGULATOR | | 1 |
| | NRV81F1-8 | REGULATOR | 1 | |
| 3 | BL023-01 | INJECTOR | | 1 |
| | BL024-01 | INJECTOR | 1 | |
| 4 | NBY28-025B3 | BURNER ASSEMBLY | | 1 |
| | NBY28-160B3 | BURNER ASSEMBLY | 1 | |
| 5 | ND1703X400X4 | ODS | | 1 |
| | ND1908X400X4 | ODS | 1 | |

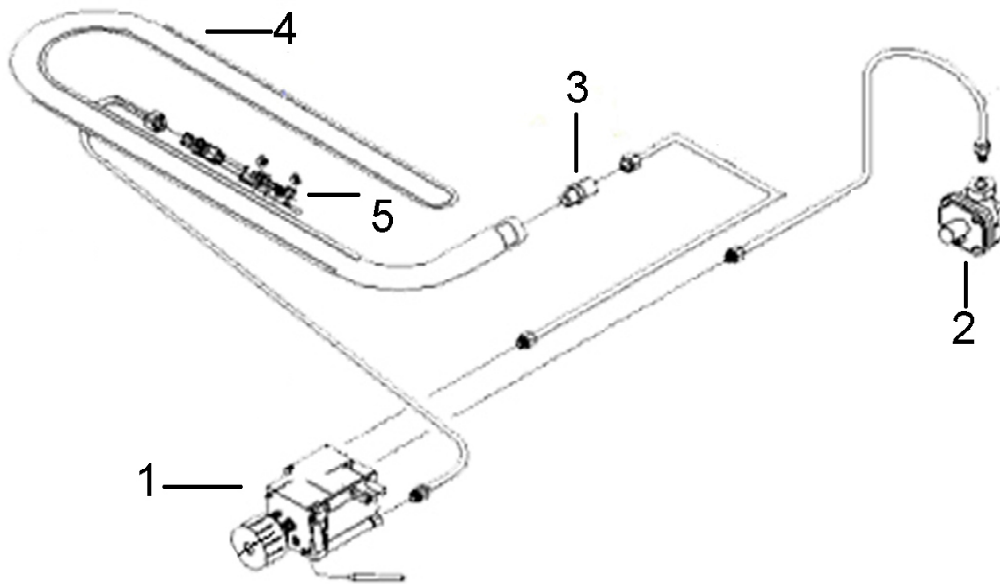

PARTS LIST

GFNC3025 GFPC3026

This list contains replaceable parts used in your heater. When ordering parts, follow the instructions listed under *Replacement Parts* on page 17 of this manual.

| KEY NO | PART NUMBER | DESCRIPTION | QUALITY | |
|--------|-------------|---------------------|---------|----|
| | | | LP | NG |
| 1 | BB26000 | LOGS | 1 | 1 |
| 2 | FB280AC6-01 | TOP PANEL | 1 | 1 |
| 3 | FB280AC6-03 | SIDE PANEL | 1 | 1 |
| 4 | FB280AC6-04 | SIDE PANEL | 1 | 1 |
| 5 | FB280AC6-05 | BASE | 1 | 1 |
| 6 | FB280AC6-02 | UPPER PANEL | 1 | 1 |
| 7 | FBL001-01 | BODY TOP COVER | 1 | 1 |
| 8 | FBL008-01B | BAFFLE | 1 | 1 |
| 9 | FBL006-01B | SIDE REFLECTOR | 2 | 2 |
| 10 | FBL007-01A | FIREBOX FLOOR | 1 | 1 |
| 11 | FBL002-01 | LOUVER | 8 | 8 |
| 12 | FBL001-03RH | BODY BOTTOM COVER | 1 | 1 |
| 13 | FBL001-02S | BODY BOARDING | 1 | 1 |
| 14 | FBL010-01B | UPPER PANEL | 1 | 1 |
| 15 | FBB102 | SCREEN | 1 | 1 |
| 16 | ML083-02 | IGNITOR | 1 | 1 |
| 17 | FBL015-01 | T-STA VALVE BRACKET | 1 | 1 |
| 18 | QL016-03R | BLOWER MOUNT PANEL | 1 | 1 |
| 19 | PF06-YJLF-F | FAN | 1 | 1 |

